

# 800<sup>Plus</sup>

## Universal Digital Counter

### Series 2

# INSTRUCTION MANUAL



**YOKOGAWA** ◆  
Yokogawa Corporation of America

2 Dart Rd, Newnan, GA 30265, USA  
Phone: 770-251-8700, Fax: 770-251-2088  
<http://www.yca.com>

# 1. ORDERING GUIDE

Configure a model number in this format: **850200FR**

**8....800<sup>Plus</sup>** Counter/timer/serial input meter  
Includes screw terminal connectors.

**Processors & Display Color**

- 5..... Basic, Green LED
- 6..... Basic, Red LED
- 7..... Extended, green LED
- 8..... Extended, red LED

**Note:** "Extended" adds custom curve linearization and other capabilities as indicated.

**Power**

- 0..... 95-240Vac, 95-300 Vdc
- 1..... 10-48 Vdc, 10-34 Vac

**Setpoint Output**

- 0..... None
- 1..... Dual 8A contact relays
- 2..... Dual solid state relays

**Analog Output**

- 0..... None
- 1..... 4-20 mA, 0-10 Vdc

**Digital Interface**

- 0..... None
- 1..... RS232
- 2..... RS485
- 3..... Parallel BCD
- 4..... RS485-Modbus

**Signal Conditioner**

- None**.....6-Digit Remote Display
- FR**..... Dual Channel Pulse or AC Input

**Basic counter**

Frequency (2 channels), rate (2 channels), total (up or down, 2 channels), period (2 channels), stopwatch, time interval, square root of rate, or 6-digit remote display.

**Extended counter**

Above plus rate and total simultaneously, custom curve linearization, arithmetic functions (A\*B, A/B, A+B, A-B, A/B-1), phase angle, duty cycle, up/down counting, batch control.

**Process Receiver & Totalizer Signal**

- VF1**..... 4-20mA
- VF2**..... 0-1mA
- VF3**..... 0-10V

**Basic counter**

Rate, square root of rate (use with differential pressure or target type flow meters), process signal totalizer.

**Extended counter**

Above plus custom curve linearization, batch control, time based on rate.

**Quadrature Input**

**QD**..... Position, length, rate

**Basic counter**

Position or length from encoders. Accepts differential or single-ended inputs: 1x, 2x or 4x, plus zero index.

**Extended counter**

Above plus bidirectional rate (rate and position are not simultaneous).

**Options**

- EB** ..... Extra bright red LED display
- BL** ..... Blank lens, no button pads

**Accessories**

- CBL01** .....RJ11-to-DB9 RS232 cable.  
Connects meter to PC com port.
- CBL02**.....USB-to-DB9 adapter.  
For use with CBL01.

## 2. TABLE OF CONTENTS

1.	ORDERING GUIDE.....	2
2.	TABLE OF CONTENTS .....	3
3.	PRODUCT INTRODUCTION .....	4
4.	RECEIVING & UNPACKING .....	5
5.	SAFETY CONSIDERATIONS .....	5
6.	CONNECTOR WIRING INFORMATION.....	6
7.	MECHANICAL ASSEMBLY .....	8
8.	FRONT PANEL SETUP KEYS.....	10
9.	ENABLING & LOCKING OUT MENU ITEMS.....	12
10.	DUAL CHANNEL PULSE OR AC INPUT SIGNAL CONDITIONER (FR) .....	13
11.	PROCESS RECEIVER & TOTALIZER SIGNAL CONDITIONER (VF) .....	30
12.	QUADRATURE SIGNAL CONDITIONER (QD) .....	38
13.	SERIAL INPUT METER / REMOTE DISPLAY (NO SIGNAL CONDITIONER) .....	47
14.	DUAL RELAY OUTPUT OPTIONS .....	49
15.	ANALOG OUTPUT OPTION.....	51
16.	SERIAL COMMUNICATION OPTIONS .....	52
17.	PARALLEL BCD OUTPUT OPTION .....	55
18.	EXCITATION OUTPUTS & POWER SUPPLY.....	56
19.	INSTRUMENT SETUP VIA PC .....	57
20.	CUSTOM CURVE LINEARIZATION .....	60
21.	METER CALIBRATION.....	62
22.	SPECIFICATIONS .....	63
23.	GLOSSARY OF TERMS .....	66
24.	WARRANTY.....	72

### 3. PRODUCT INTRODUCTION

**These UL-certified panel meters are versatile, cost effective solutions** to a wide range of monitoring and control applications including frequency, rate, total, period, time, phase, position, flow, and serial input display. Setup can be via front panel pushbuttons or a PC, and allows the user to customize the meters for a specific application, with direct readout in engineering units. Selective security lockout of front panel setup protects against accidental or unauthorized setup changes, and simplifies meter use.

**A dual-channel pulse or AC input signal conditioner** and powerful firmware accommodate a wide range of applications, including rate/frequency, totalizing, timing, phase angle, and duty cycle. Frequency and rate are determined by taking the inverse of period. Fast read rate provides an accurate display of peak or valley signals, and quick response for control applications. Adaptive filtering ensures stable displayed readings and outputs while responding rapidly to actual changes of the input signal. A high stability quartz crystal and digital calibration of all ranges are used for rate and analog measurements.

**A process receiver & totalizer signal conditioner** accepts 4-20 mA, 0-1 mA or 0-10V analog signals for display of rate or position. Square root is selectable for use with differential pressure flow transducers.

**A quadrature signal conditioner** provides a highly accurate display of position, angle, or rate.

**Four communication options** (RS232, RS485, R485-Modbus, or parallel BCD output) can convert the meter from stand-alone to system use, with interface with computers, PLC's or other meters. PC-compatible Instrument Setup software is available at no charge to set up the units via the serial interface.

**Operation as a 6-digit serial input meter** is achieved with a serial interface and no signal conditioner. The unit can serve as a remote display with serial data from a computer, PLC or other meter. With a dual relay board, it can provide local alarm or On/Off control. With an analog output board, it can also serve as a local transmitter.

**The meter power supply** is a lightweight, high-efficiency switching type that can operate from either AC or DC voltages and complies with safety regulations. The standard supply allows the meters to be powered worldwide from 95 to 240 Vac  $\pm 10\%$ . An optional supply operates from batteries or low voltage sources such as 8-34 Vac.

**A built-in isolated excitation supply** with jumper-selectable 5, 10 or 24 Vdc output levels can eliminate the need for an external sensor power supply.

**The meter case** meets the 1/8 DIN size standard and is sealed to NEMA-4X (IP65) when panel mounted. Mounting is from the front of the panel and requires less than 110 mm behind the panel. All wiring is via removable plugs conforming to IEC950 safety standards. All output options are isolated from meter and power ground to 250 Vac.

**Alarm and control** can be provided by two optional Form C (8A @ 250 Vac) contact relays or two solid state relays. The relays can be configured to be latching or non-latching, and to be energized above or below the setpoint, or in a fail-safe mode.

**An analog transmitter output** scaled to the display can be provided by an optional isolated analog output board with selectable 0-20 mA, 4-20 mA and 0-10V ranges.

## 4. RECEIVING & UPACKING

Your meter was carefully tested and inspected prior to shipment. Should the meter be damaged in shipment, notify the freight carrier immediately. In the event the meter is not configured as ordered or the unit is inoperable, return it to the place of purchase for repair or replacement. Please include a detailed description of the problem.

## 5. SAFETY CONSIDERATIONS



**Warning:** Use of this equipment in a manner other than specified may impair the protection of the device and subject the user to a hazard. Visually inspect the unit for signs of damage. If the unit is damaged, do not attempt to operate.

### Caution:

- This meter must be powered with AC (mains) from 95-240 Vac  $\pm 10\%$  (90-300 Vdc) with the high voltage power supply option, or 10-34 Vac  $\pm 10\%$  (10-48 Vdc) with the low voltage power supply option. Verify that the proper power option is installed for the power to be used. This meter has no AC (mains) switch. It will be in operation as soon as power is connected.
- The 95-240 Vac (95-300 Vdc) mains connector (P1 Pins 1-3) is colored Green to differentiate it from other input and output connectors. The 10-34 Vac (10-48 Vdc) mains connector is colored Black.
- Do not make signal wiring changes or connections when power is applied to the meter. Make signal connections before power is applied. If reconnection is required, disconnect the AC (mains) power before such wiring is attempted.
- To prevent electrical or fire hazard, do not expose the meter to excessive moisture.
- Do not operate the meter in the presence of flammable gases or fumes; such an environment constitutes a definite safety hazard.
- This meter is designed to be mounted in a metal panel. Verify the panel cutout dimensions, and mount according to instructions.

### Symbols used



Caution (refer to accompanying documents)



Caution, risk of electric shock.



Equipment protected throughout by double insulation or reinforced insulation.

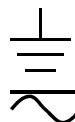

Earth (ground) terminal.



Both direct and alternating current.

### Operating environment:

The meter is Class II (double insulated) equipment designed for use in Pollution degree 2.

## 6. CONNECTOR WIRING INFORMATION

### CONNECTORS

Connectors for signal and power are U/L rated screw-clamp terminal blocks that plug into mating jacks on the printed circuit board. Communication connectors are a single RJ11 plug for RS232, dual RJ11 plugs for RS485, dual RJ45 plugs for RS485-Modbus, and a 30-pin mass termination connector for parallel BCD output.

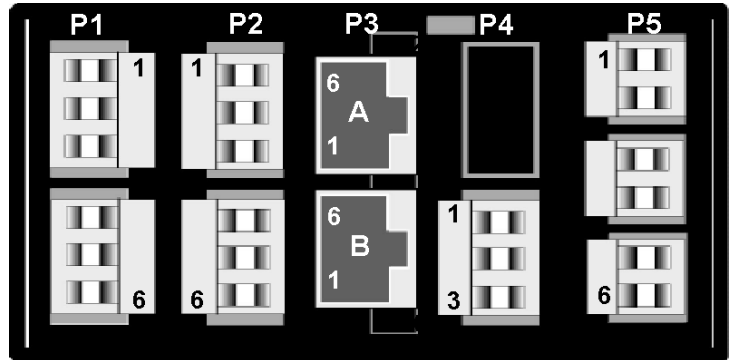

### P1 - POWER AND DIGITAL CONTROLS

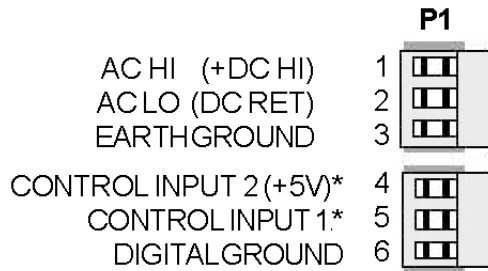

\* **Note:** external control inputs 1 and 2 are menu selectable.



**Caution:** P1, pins 4, 5, and 6 may have hazardous voltages present.

### P5 - SIGNAL INPUT

#### DUAL CHANNEL PULSE INPUT

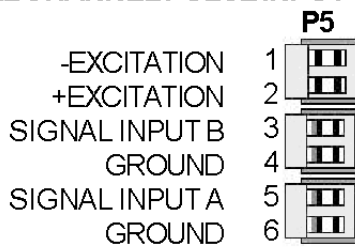

#### QUADRATURE INPUT (DIFFERENTIAL)

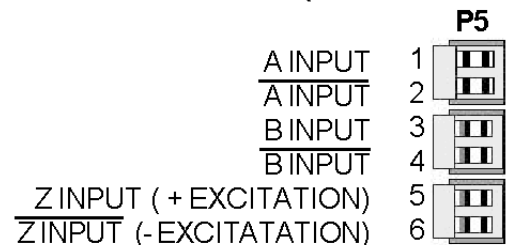

**Note:** Z input or excitation is jumper selectable

#### VOLTAGE-TO-FREQUENCY CONVERTER

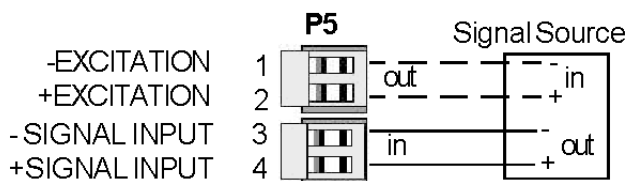

#### QUADRATURE INPUT (SINGLE-ENDED)

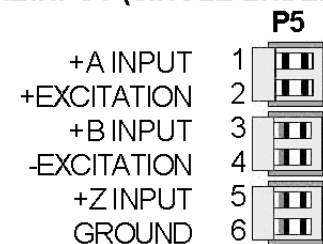

## P2 - DUAL SETPOINT CONTROLLER

### RELAY OUTPUTS (Rev J and earlier)

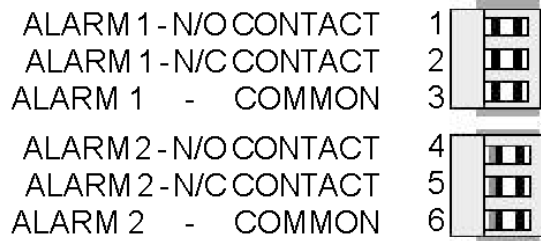

### RELAY OUTPUTS (Rev K and later)

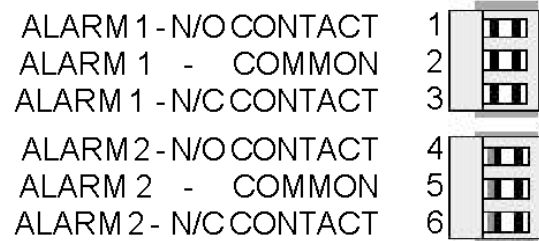

### SOLID STATE RELAY OUTPUTS (Rev J and earlier)

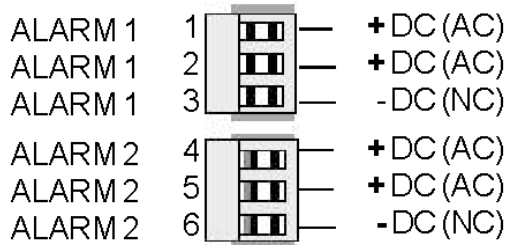

### SOLID STATE RELAY OUTPUTS (Rev K and later)

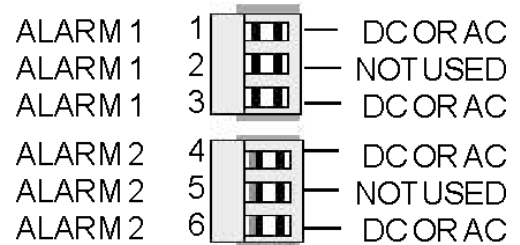

## P3 - SERIAL COMMUNICATIONS

### RS232 INTERFACE Computer

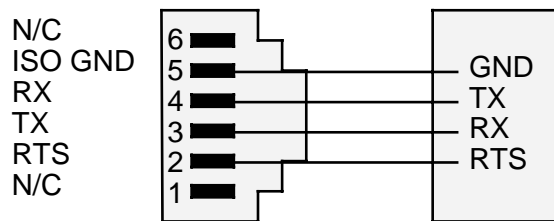

### P4 - ANALOG OUTPUT

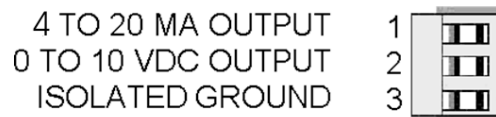

### RS485 INTERFACE - FULL DUPLEX

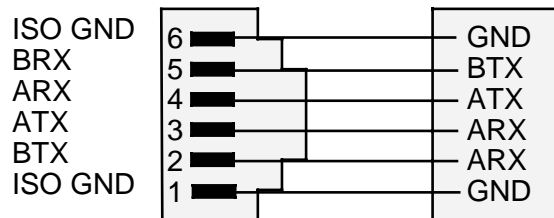

### RS485 INTERFACE - HALF DUPLEX

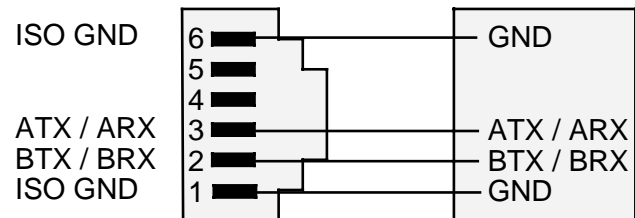

### RS485-MODBUS - FULL DUPLEX

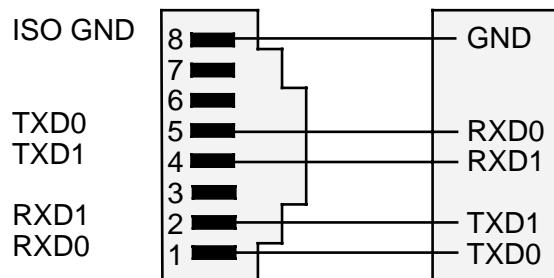

### RS485-MODBUS - HALF DUPLEX

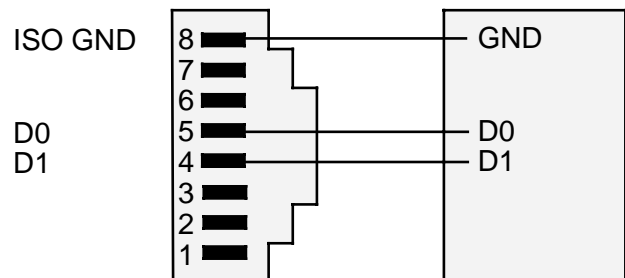

## 7. MECHANICAL ASSEMBLY

### REMOVING THE REAR PANEL

First remove any connectors. Use one hand to press in the two sides of the rear of the case, and the other hand to press down the two protruding tab releases at the top of the rear panel (see figure below). This will unhook the rear panel from the case.

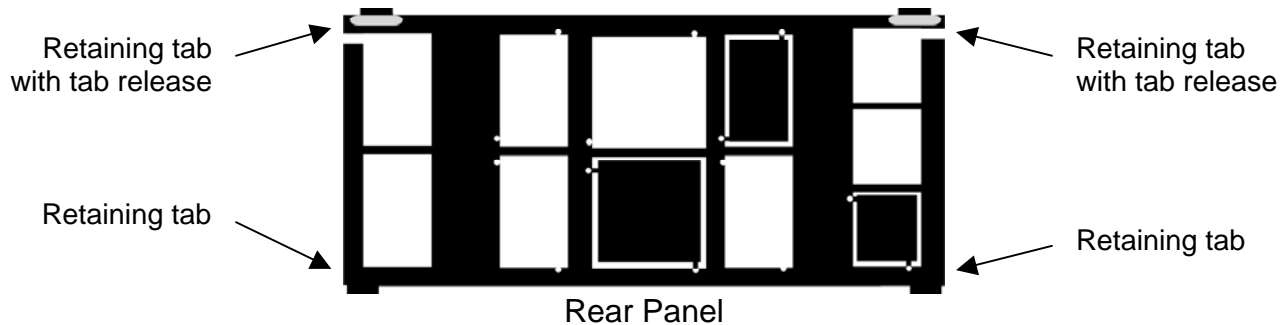

### REMOVING THE ELECTRONICS

With the rear panel removed, grasp the power supply board to the left and signal conditioner board to the right, and carefully slide the electronic assembly out through the rear of the case. (see figure below).

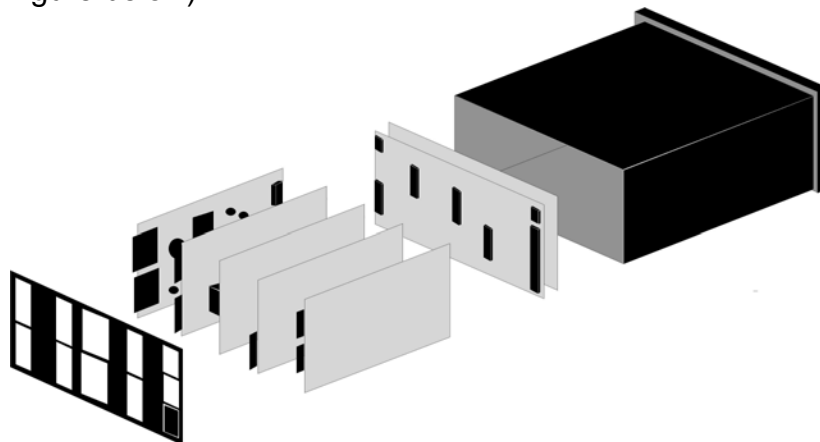

### INSTALLING NEW OPTION BOARDS

Options boards plug into the main board at the front of the meter. These are plug-and-play and may be installed in the field. They will be recognized by the software, which will provide access to the menu items associated with that board. If necessary, remove rear panel knockouts for new boards. Boards plug into connectors as follows:

Option Board	Main Board Plug	Rear Panel Jack
Power supply	P11	J1
Relay board	P12	J2
Serial interface board	P13	J3
Analog output board	P14	J4
Signal conditioner board	P15	J4



**Note:** Corresponding main board and option board connectors have the same number of electrical lines. When an option board is correctly installed, the top and bottom edges of the main board and option board are aligned.

## REASSEMBLING YOUR METER

Slide the electronics assembly into the case until the display board is seated flush against the front overlay. Insert the bottom tabs of the rear panel into the case, then carefully align the board connectors with the openings in the rear panel. If necessary, remove any rear panel knockouts for new option boards that may have been installed. Ensure that all option boards are properly aligned with the molded board retaining pins on the inside of the rear panel. Once the rear panel is in place, reinstall the input/output screw clamp terminal plugs.

## PANEL MOUNTING

Ensure that the panel mounted gasket is in place against the back of the bezel. Turn the two mounting screws counterclockwise until the space between the mounting pawl and the rear of the gasket is greater than the panel thickness. Insert the meter in the panel cutout. Turn the mounting screws clockwise until the meter is securely mounted in the panel. Do not overtighten.

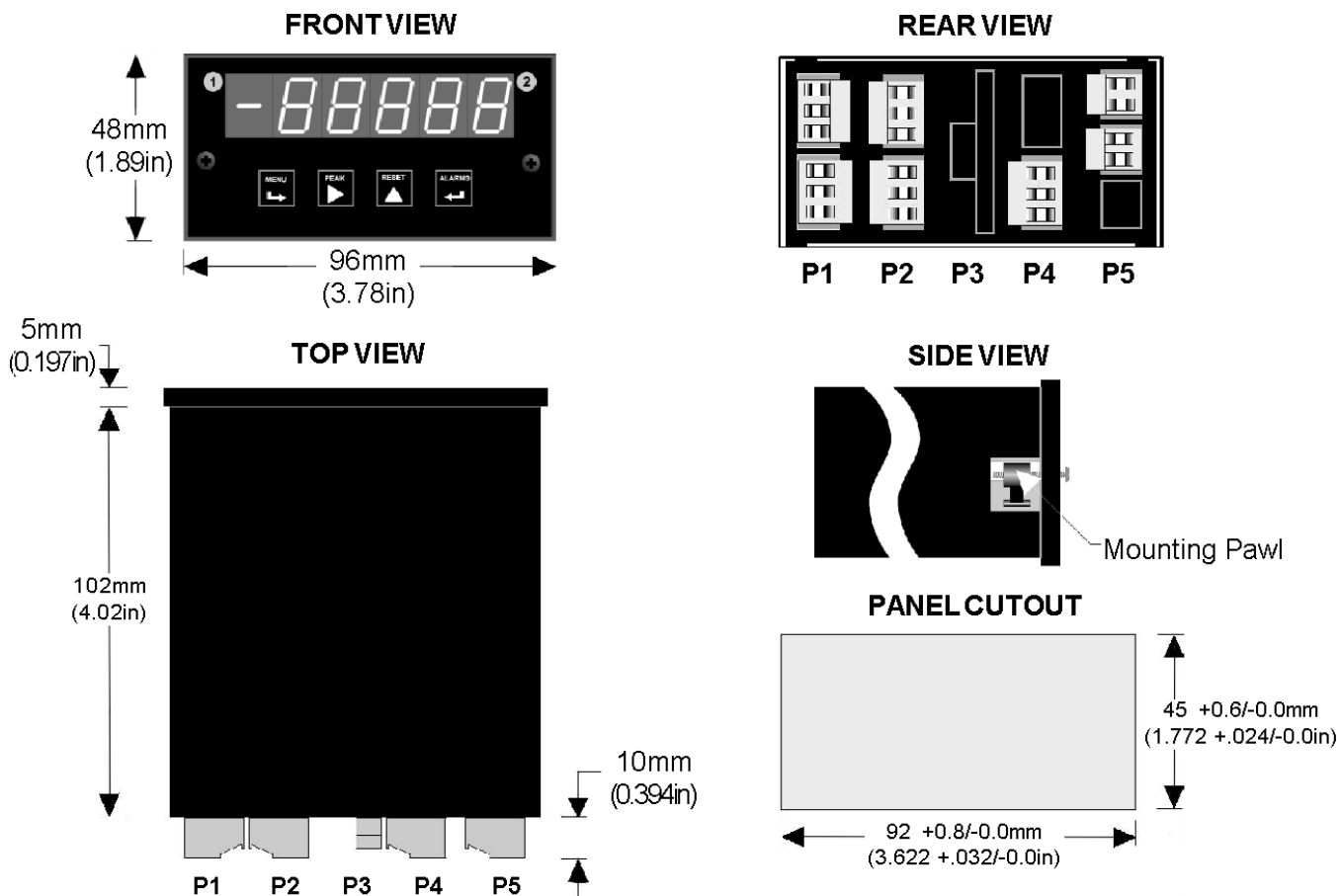

*Dimensioned case drawings*

## 8. FRONT PANEL SETUP KEYS



Counter Front Panel

There are four front panel keys, which change function for the **Run Mode** and **Menu Mode**, effectively becoming eight keys. The keys are labeled with alphanumeric captions (MENU, PEAK, RESET, ALARMS) for the Run Mode and with symbols (← right arrow, ► right triangle, ▲ up triangle, ← left arrow) for the Menu Mode.

### FRONT PANEL LOCKOUT

The Menu Mode will not work with most meters shipped from the factory, since all menu items have been disabled in software and a lockout jumper is in place. This jumper needs to be removed for the Menu Mode to work, and values under **Loc 1** through **Loc 4** need to be set to "0" via the front panel for these menu items to be available. See Section 9. The paragraphs below assume that all lockout features have been removed.

### MENU MODE KEY ACTION

In the Menu Mode, pressing a key momentarily advances to the next menu item. Holding down a key automatically advances through multiple menu items for fast menu navigation.

### KEYS IN RUN MODE

**MENU Key.** Pressing *MENU* from the Run Mode enters the Menu Mode. Pressing *MENU* repeatedly will step the meter through the various menu items (if these have not been locked out) and then back to the Run Mode.

**PEAK Key.** Pressing *PEAK* causes the peak value of the input signal to be displayed. The peak display blinks to differentiate it from the normal present value display. Pressing *PEAK* again will return the display to the present value.





**RESET Key.** Pressing *RESET* with *PEAK* resets peak and valley values. Pressing *RESET* with *ALARMS* resets latched alarms. Pressing *RESET* with *MENU* performs a meter reset (same as power on). Pressing and releasing *RESET* without pressing another key changes the displayed item if the mode has multiple items. For Item 1, the V LED is out. For Item 2, the V LED is on. For Item 3, the V LED is flashing.



**ALARMS Key.** Pressing *ALARMS* once displays the setpoint for Alarm 1. Pressing it again displays the setpoint for Alarm 2. Pressing it again returns to the present value. After 30 seconds, the meter automatically returns to the present value. Timing is automatically reset whenever the *ALARMS* key is pressed.





## KEYS IN MENU MODE



**Right Arrow Key (MENU).** Pressing  steps the meter through all menu items that have been enabled and then back to the Run Mode. With the dual-channel pulse input signal conditioner board and no option boards, available menu items will be **InPut**, **SEtuP**, **ConFiG**, **dSPYnc**, etc. Actual menu items will vary depending on the *Input* selection and boards detected in the meter. If a change has been made to a menu item, that change is saved to non-volatile memory when the  key is pressed next, and **StoreE** is displayed briefly.





**Right Triangle Key (Digit Select).**

- Pressing  from the *InPut* menu brings up all meter functions available with the meter's signal conditioner. For the dual-channel pulse input signal conditioner, these are **rAtE**, **PEriod**, **totAL**, **ti\_Int**, **Stop t**, **PHASE**, **duty C**.
- Pressing  from most menus selections sequentially selects digit positions 1 - 6, as indicated by a flashing digit: **000000**, **000000**, **000000**, **000000**, **000000**, **000000**.
- Pressing  from *dEC.Pt1* brings up a decimal point display of type **11.1111**. Pressing  from *dEC.Pt2* brings up a decimal point display of type **22.2222**.



**Up Triangle Key (Value Select).**

- Pressing  from a selected meter function, such as **rAtE**, will select the a specific operating mode within that function, such as **A\_OnLy**. Always press the MENU key to save your selection. Do not press the  key to the right, or your selection will be lost.
- Pressing  for a flashing digit position or decimal point position will increment that item. Pressing the MENU key will save any changes.



**Left Arrow Key (Reverse Menu).** Pressing  has the same effect as the MENU key, except that menu items are brought up in reverse order.

## 9. ENABLING & LOCKING OUT MENU ITEMS

For security reasons and ease of operation, any and all menu items may be disabled or "locked out" so that they are no longer directly accessible from the front panel. Each function to be enabled is set to "0" and each function to be disabled is set to "1" in menu items *Loc 1-4*. These menu items can in turn be locked out by installing an internal hardware jumper. With the jumper installed, the operator only has access to enabled menu items. With the jumper removed, the operator also has access to the *Loc 1-4* menu items.

### SETTING HARDWARE LOCKOUT JUMPER

To access the lockout jumper, remove the rear panel per Section 9 and locate jumper "a" in the lower portion of the power supply board next to the input connectors (see figure at right).

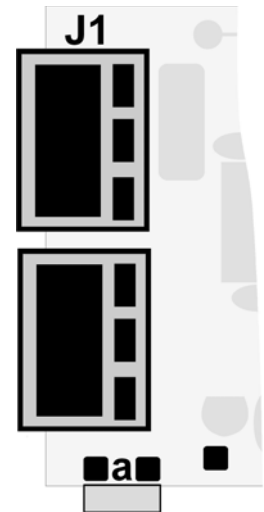

### SETTING SOFTWARE LOCKOUTS

When setting up the meter, it may be necessary to enable specific menu items by setting the corresponding lockout digit to 0. Be sure to reset the lockout digit to "1" if you do not want the menu item to be changed by an operator.

#### **Loc 1** **Loc 2** **Loc 3** **Loc 4**

Press the **→** MENU key until *Loc 1*, *Loc 2*, *Loc 3* or *Loc 4* is displayed, as desired. **Note:** the lockout jumper must be removed (see above).

#### **111111**

Press **▶** to display the lockout status, consisting of 0's and 1's. The left digit will flash. Press **▶** again to step to the next digit, which will flash.

#### **000000** 123456

Press **▲** to set the flashing digit to "0" to enable the menu item or to "1" to disable. Press *MENU* to enter. See the table to the right for list of menu items that can be enabled or disabled.

### Enabled / Disabled Menu Items

#### **Loc 1**

- 3 - Input type selection
- 4 - Setup, Config, Dspyno
- 5 - Gate time, timeout, batch setup
- 6 - Filter setup

#### **Loc 2**

- 3 - Slope, decimal points
- 4 - Scale, offset, resolution, 2-coord.
- 5 - Alarm config, DevHy
- 6 - Alarm setpoint programming

#### **Loc 3**

- 3 - Analog output setup & scaling
- 4 - Serial communications configuration
- 5 - Calibration
- 6 - Change displayed Item #

#### **Loc 4**

- 3 - View peak value
- 4 - View alarm setpoints
- 5 - Front panel resets (peak & latched alarms)
- 6 - Front panel reset (cold reset only)

## 10. DUAL CHANNEL PULSE OR AC INPUT SIGNAL CONDITIONER (FR)

The dual channel signal conditioner board is used for the frequency, rate, period, timing, batch control, phase and duty cycle meter functions. The board needs to be configured via jumpers for the input signal type and level. It is recognized by the meter software, which will bring up the applicable menu items. The dual channel pulse input signal conditioner does not require calibration, since the quartz crystal oscillator used for frequency and timing applications is located on the counter main board.

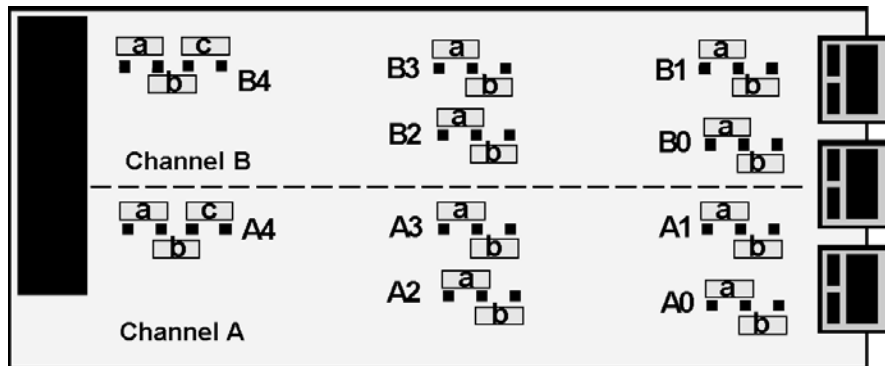

### Jumper Settings for Expected Signal Levels

The jumper settings for Channel A (A2 & A3) and Channel B (B2 & B3) need to be set for the expected signal voltage. This voltage must be outside of the high and low thresholds per the following table, or the meter will not operate properly. The larger the difference between the high and low thresholds, the more immune the meter is to input signal noise.

A3 B3	A2 B2	Input must be		A3 B3	A2 B2	Input must be		A3 B3	A2 B2	Input must be	
		above	below			above	below			above	below
-	a	-12 mV	+12 mV	a	a	+30 mV	+60 mV	b	a	-60 mV	-30 mV
-	b	-150 m	+150 mV	a	b	+350 mV	+600 mV	b	b	-600 m	-350 m
-	-	V	+1.15V	a	-	+1.25V	+2.1V	b	-	V	V
		-1.15V								-2.1V	-1.25V

### Jumper Settings for Frequency Response, Bias Resistor, Debounce Time

Pull-up or pull-down resistors are used with open collector devices and dry contact closures to provide input signal bias. They should not be connected for other inputs. Debounce circuitry keeps the meter from counting extra pulses due to contact bounce.

Function	Block	Jumper	Setting
Frequency Response	A0 & B0	- b a	1 MHz max 30 kHz max 250 Hz max
Bias Resistor	A1 & B1	a b	10 kOhm pull-up to 5V 10 kOhm pull-down to -5V
Contact Debounce	A4 & B4	b a, c	None 3 msec

		c	50 msec
--	--	---	---------

## Common Jumper Settings

Input Type	Vmax	A0 & B0	A1 & B1	A2 & B2	A3 & B3	A4 & B4
Logic levels	250V	-	-	-	a	b
NPN open collector	NA	b	a	-	a	b
PNP open collector	NA	b	b	-	b	b
Contact closures	NA	a or b	a	-	a	a, c
Line frequency	250V	b	-	-	-	a, c
Turbine flow meter	250V	b	-	a	-	b

## OVERVIEW OF OPERATING MODES

### RATE & FREQUENCY MODES

**Frequency in Hz** is determined by timing an integral number of pulses over a user-specified *gate time* from 0 to 199.99 sec and taking the inverse of average period. The typical display update rate of the meter is gate time + 1 period + 30 ms. Selecting a longer gate time produces a more stable reading as more cycles are averaged, but slows down the update rate. At very low frequencies, the update rate is controlled by the period. A *time-out* from 0 to 199.99 sec is also selectable. This is the time the meter waits for a signal to start or end a conversion. If the signal is not received before the *time-out* ends, the meter reads zero. The longer the time-out, the lower the minimum frequency the meter can display.

With a *scale factor* of 1 and *multiplier* of 1, frequency is displayed in Hz with no decimal point. Applying a multiplier from 1 to 100000 (in decade steps) and setting the decimal point increases resolution (0.1 to 0.00001 Hz). Decreasing the multiplier from 1 to 0.00001 (in decade steps) and setting the decimal point allows display in kHz or MHz. Note that the same 100 kHz frequency can be displayed as 100000 Hz or 100.000 kHz simply by moving the decimal point.

### DISPLAY FREQUENCY IN Hz WITH 1 Hz RESOLUTION

Dig. No.	S	1	2	3	4	5	6								
InPut				r	A	t	E	A	O	n	L	y			
SEtuP		0	0	0	0	0	0								
ConFiG				1	0	0	0								
dSPyno						0	1								
GAtE t			0	0	0.	2	2								
ti Out			0	0	1.	0	0								
FILtEr			0	0	1	0	5								
SLOPE						0	1								
DecPt1		1	1	1	1	1	1.								
SCALE1		1.	0	0	0	0	0							1	
OFFSt1		0	0	0	0	0	0								
CALib	-		0	0	0	0	0	Do Not Change Calib							

**Application:** Display frequency from 1 Hz to 999999 Hz with no decimal, display update rate of 4/sec, and adaptive moving average filter for 6 readings.

**Solution:** Set Input to "Rate A Only." Set Config to display to 999999 counts. Set Gate Time to .22 sec so that the display update rate becomes .22 sec +30 ms +1 period. Set Time-out to 1 sec, so that frequencies under 1 Hz are displayed as 0. Set filter for adaptive moving average with a 1.6 sec time constant. Apply a scale value of 1.00000 and multiplier of 1 for direct readout in Hz.

## DISPLAY 0-50.00 RATE FROM 1-10 kHz INPUT, COORDINATES OF 2 POINTS METHOD

Dig. No.	S	1	2	3	4	5	6
InPut				r	A	t	E
SEtuP			0	0	1	0	0
ConFiG				1	0	0	0
dSPyno						0	1
GAtE t			0	0	0.	2	2
ti Out			0	0	1.	0	0
FILtEr			0	0	1	0	5
SLOPE						0	1
DecPt1		1	1	1	1.	1	1
Lo In1		0	0	1	0	0	0
Lo rd1		0	0	0	0.	0	0
Hi In1		0	1	0	0	0	0
Hi rd1		0	0	5	0.	0	0
CALib	-		0	0	0	0	0

Do Not Change Calib

**Application:** Display 0-50.00 (with two decimal places) for 1-10 kHz input. Use coordinates of 2 points scaling method.

**Solution:** Set Input to “Rate A Only.” Select “coordinates of 2 points” scaling method under Setup. This is easier than scale and offset. Set DecPt1 to two places. Then enter the low input and desired low reading, and high input and desired high reading, as shown.

## DISPLAY RATE IN GPM FROM 36.67 PULSE/GALLON TURBINE FLOW METER

Dig. No.	S	1	2	3	4	5	6
InPut				r	A	t	E
SEtuP			0	0	1	0	0
ConFiG				1	0	0	0
dSPyno						0	1
GAtE t			0	0	0.	2	2
ti Out			0	0	0.	1	0
FILtEr			0	0	1	0	5
SLOPE						0	1
DecPt1		1	1	1	1.	1	1
Lo In1		0	0	0	0	0	0
Lo rd1		0	0	0	0.	0	0
Hi In1		0	0	3	6.	6	7
Hi rd1		0	0	6	0.	0	0
CALib	-		0	0	1	0	0

Do Not Change Calib

**Application:** Display rate in GPM to two decimal places from flow meter calibrated to 36.67 pulses/gallon.

**Solution:** Set Input to “Rate A Only. Under Setup, select “coordinates of 2 points” scaling method. Set DecPt1 to two places. Then enter the low input and desired low reading, and high input and desired high reading, as shown. In this example, we want to display 60.00 (GPM) from an input of 36.67 Hz. Note that the meter’s native rate measurements are in Hz. There will be 60 times more gallons per minute than per second.

**Rate in engineering units** is displayed from measured frequency by applying an appropriate *scale factor* and setting the decimal point. The *scale factor* consists of a *scale value* from 0.00000 to 9.99999 (fixed decimal point and settable digits) and a *scale multiplier* from 0.00001 to 100000 (in decade steps). When using the *coordinates of 2 points method* to scale the meter, the low input and high input frequencies are entered in Hz.

- **RATE A ONLY (A\_OnLy)** displays rate or frequency for Channel A. The latter utilizes *SCALE1*, *OFFSt1* and *dECPt1*. Channel B is not used.
- **RATE A B (A\_\_b\_\_)** displays rate or frequency for Channel A as Item #1 or for Channel B as Item #2. The latter utilizes *SCALE2*, *OFFSt2* and *dECPt2*.
- **RATE A, TOTAL A (A\_Atot)** (Extended counter) displays Rate for Channel A as Item #1 and Total for Channel A as Item #2 since last reset. Total may count down from an offset by entering a negative scale factor. Only used for non-linear inputs.

- **RATE A, TOTAL B (A\_btot)** (Extended counter) displays Rate for Channel A as Item #1 and Total for Channel B as Item #2.
- **RATES A+B, A-B, AxB, A/B, A/B-1** (Extended counter) display arithmetic combinations of Rates A and B as Item #1, Rate A as Item #2, and Rate B as Item #3. With rates A and B scaled to produce a ratio close to 1 and an offset of -1, the special combination A/B-1, called “Draw,” can display percentage changes, such as elongation of material as it passes between rollers.

## TOTAL MODES

### DISPLAY TOTAL IN GALLONS FROM 36.67 PULSE/GALLON TURBINE FLOW METER

Dig. No.	S	1	2	3	4	5	6										
InPut				t	o	t	A	L	A					O	n	L	y
SEtuP			1	0	1	0	0	0									
ConFiG				1	0	0	0	0									
dSPyno							0	1									
GAtE t			0	0	0.	0	0	1									
SLOPE							0	1									
DecPt1		1	1	1	1.	1	1	1									
Lo In1		0	0	0	0	0	0	0									
Lo rd1		0	0	0	0.	0	0	0									
Hi In1		0	0	3	6.	6	7										
Hi rd1		0	0	0	1.	0	0										
CALib	-		0	0	0	0	0	0	Do Not Change Calib								

**Application:** Display total in gallons with two decimal places for flow meter calibrated to 36.67 pulses/gallon.

**Solution:** Set Input to “Total A Only.” Under Setup, select “Restore totals at power-on” and coordinates of 2 points method. This is the preferred scaling method. Set gate time to its minimum of 0.01 sec for smooth display updates. Set DecPt1 to two places. Then enter low input and desired low reading, and high input and desired high reading for display of 1.00 for 36.67 pulses, as shown.

### DISPLAY SIMULTANEOUS RATE & TOTAL FROM 36.67 PULSE/GALLON FLOW METER

Dig. No.	S	1	2	3	4	5	6										
InPut				r	A	t	E	A	A	t	o	t					
SEtuP			1	0	1	1	0										
ConFiG				1	1	0	0										
dSPyno							0	1									
GAtE t			0	0	0.	1	0										
ti Out			0	0	1.	0	0										
FILtEr			0	0	1	0	5										
SLOPE							0	1									
DecPt1		1	1	1	1.	1	1										
DecPt2		2	2	2	2	2	2.										
Lo In1		0	0	0	0	0	0										
Lo rd1		0	0	0	0.	0	0										
Hi In1		0	0	3	6.	6	7										
Hi rd1		0	0	6	0.	0	0										
Lo In2		0	0	0	0	0	0										
Lo rd2		0	0	0	0	0	0										
Hi In2		0	0	3	6.	6	7										
Hi rd2		0	0	0	0	0	1										
CALib	-		0	0	0	0	0	Do Not Change Calib									

**Application:** Display flow rate in GPM with two decimal places and total gallons with no decimal places from the same flow meter signal calibrated to 36.36 pulses/gallon, applied to Channel A

**Solution:** Use an Extended counter, as required for simultaneous rate and total. Set Input to “Rate A A Total.” For flow rate in GPM (Item #1), set DecPt1 to two decimals, and scale the display by entering Lo In1, Lo rd1, Hi In1, Hi rd1 as shown. For total in Gallons (Item #2), set DecPt2 to no decimals, and scale the display by entering Lo In2, Lo rd2, Hi In2, Hi rd2 as shown. Enter a Gate Time, such as 0.1 sec, which is long enough to produce stable rate readings, but is short enough to produce rapid updates of total.



## DISPLAY TOTAL VOLUME BY ADDING TWO TURBINE FLOW METER CHANNELS

Dig. No.	S	1	2	3	4	5	6						
InPut			t	o	t	A	L	A		+		b	
SEtuP			1	0	1	1	0						
ConFiG				1	1	0	0						
dSPyno						0	1						
GAtE t			0	0	0.	0	1						
SLOPE						0	0						
DecPt1		1	1	1	1.	1	1						
DecPt2		2	2	2	2.	2	2						
Lo In1		0	0	0	0	0	0						
Lo rd1		0	0	0	0.	0	0						
Hi In1		0	0	3	6.	6	7						
Hi rd1		0	0	0	1.	0	0						
Lo In2		0	0	0	0	0	0						
Lo rd2		0	0	0	0.	0	0						
Hi In2		0	0	5	8.	1	2						
Hi rd2		0	0	0	1.	0	0						
rESoLn							1						
CALib	-		0	0	0	0	0	Do Not Change Calib					

**Application:** Display total liquid volume in gallons to two decimal places from 2 pipes dispensing liquids into the same tank. Flow meter A is calibrated to 36.67 pulses/gallon, flow meter B to 58.12 pulses/gallon.

**Solution:** Arithmetic operations require the Extended counter. Apply flow meter output A output to Channel A, flow meter output B to Channel B. Set Input to "Total A+B." Set Gate Time to 0.01 sec for fast display updates. Select a positive trigger slope for A and B. Set DecPt2, which applies to Grand Total, and DecPt1, which applies to Totals A and B, both to two decimal places. Under Setup, select the coordinates of 2 points scaling method for A and B. To scale A, enter 36.67 (pulses) for Hi In1 and 1.00 (gallons) for Hi Rd1. To scale B, enter 58.12 (pulses) for Hi In2 and 1.00 (gallons) for Hi Rd2. The normal display will be Item #1 (Grand Total). Press the ▲ key to view Item #2 (Total A) and Item #3 (Total B).

**TOTAL A ONLY (A\_OnLy)** displays the number of pulses applied to Channel A as Item #1. If scientific notation is not selected, overflows beyond 999,999 are recorded in units of 1,000,000 as Item #2. For example, a total of 17,345,676 would be displayed as 345,675 in Item #1 and 17 in Item #2. This capability gives the counter 12-digit capability. Items #1-2 can also be retrieved via serial communications.

- **TOTAL A B (A\_\_b\_\_)** displays Total A as Item #1 or Total B as Item #2.
- **TOTALS A+B, A-B, AxB, A/B** (Extended counter) display arithmetic combinations of Totals A and B as Item #1, Total A as Item #2, and Total B as Item #3.
- **TOTAL A-B UD (A-b\_Ud)** is the same as TOTAL A-B, except that counts are subtracted on an ongoing basis, instead of subtracting totals. This avoids round-off errors with large totals.
- **BURST (\_burST)** (Extended counter) displays the total number of signal bursts applied to Channel A as Item #1 and signal frequency within a burst as Item #2. Gate time must be greater than the period of the lowest signal frequency and less than the minimum time between bursts. Time-out must be greater than the maximum time between bursts.
- **TOTAL A B U/D (A\_bU/d)** (Extended counter) displays Total A as Item #1, where the up or down count direction is determined by an input on Channel B. If the menu item *SLOPE* is set to 0 for Channel B, (digit 6), an input level on B below the jumper set Low Threshold B causes the count to go up, and an input level above the jumper set High Threshold causes the count to go down. If *SLOPE* for Channel B is set to 1, the opposite occurs. The maximum frequency on A that can be counted is 250 kHz, or a minimum of 4 µs between pulses.

- **TOTAL A B INHIBIT (A\_bInH)** (Extended counter) displays Total A as Item #1, where counting may be inhibited by a control input on Channel B. If the menu item *SLOPE* is set to 0 for Channel B (digit 6), a low input level on B allows counting, and a high input level inhibits counting. If the *SLOPE* for Channel B is set to 1, the opposite occurs. The maximum frequency on A that can be counted is 1 MHz.

## BATCH CONTROL MODE (\_bAtCH)

### BATCH CONTROL WITH A 36.67 PULSE/GALLON TURBINE FLOW METER

Dig. No.	S	1	2	3	4	5	6
InPut				r	A	t	E
SEtuP		1	0	0	1	0	
ConFiG			1	1	0	0	
dSPyno						0	1
GATe t		0	2	0.	0	0	
bAtCH		1	0	0	1	0	
FILtEr		0	0	1	0	5	
SLOPE						0	0
DecPt1	1	1	1	1.	1	1	
DecPt2	2	2	2	2.	2	2	
SCALE1	2.	7	2	7	0	2	
OFFSt1	0	0	0	0	0	0	
Lo In2	0	0	0	0	0	0	
Lo rd2	0	0	0	0.	0	0	
Hi In2	0	0	3	6.	6	7	
Hi rd2	0	0	6	0.	0	0	
rESoLn							1
Source			1	1			
AL SET		0	0	2	4	0	
dEU n1b	0	0	0	0.	0	0	
dEU n2b	0	0	0	0.	0	0	
CALib	-	0	0	0	0	0	

Do Not Change Calib

ALARM KEY	S	1	2	3	4	5	6
SETPT1	0	0	5	4.	0	0	
SETPT2	0	0	5	5.	0	0	

**Application:** Fill 55 gallon tanks, measuring flow with a 36.67 pulses/gallon flow meter. Slow down filling at 54 gallons. Cycle batches automatically with 20 sec between cycles. Display batch total & fill rate to 2 places. Track number of batches.

**Solution:** Use an Extended counter with a dual relay output board. Apply the flow meter signal to Channels A & B. Set Input to "Rate Batch." Set Batch to count up to Setpoint1. Use Gate Time as delay between batches. Make Item #2 the number of batches. Set Gate Time to 20 sec. Set an adaptive moving average filter, which will apply to rate only, not totals. Set DecPt1 and DecPt2 to two decimal places for Items #1 and #3 (Batch Total and Rate). Scale Item #1 (Batch Total) by entering a Scale1 of 2.72702 (counts per pulse) and a Setpoint1 of 55.00, which will serve as the batch setpoint in gallons. Scale Item #3 (Rate) using the coordinates of 2 points method so that 36.67 pulses/sec will be displayed as 60.00 GPM. Set Setpoint2 to 54.00 to activate Relay 2 to slow the fill rate at 54.00 gallons.

**Batch control** (Extended counter) uses the meter with a dual relay controller board to control repetitive fill operations. Relay #1 is used as the batch relay. Relay #2 (or Setpoint #2) can be assigned to another limit, such as pre-warn to slow filling near the setpoint, end-of-process, or rate alarm. The same signal is applied to Channels A and B. When digit 6 of *bAtCH* (Action after Meter Reset) is set to zero, the following applies:

- **In batch control mode without external resets**, the meter waits until the *RESET* key is pushed. It then energizes Relay #1 and displays the changing Batch Total. When the preset value is reached, Relay #1 de-energizes for the duration of the gate time setting. Relay #1 then re-energizes, the Batch Total resets, and the fill cycle repeats.
- **In batch control mode with external resets**, pushing the *RESET* key initiates cycling. Grounding an external *Gate* input for a minimum of 3.33 ms then starts each new fill cycle by energizing Relay #1 and resetting the Batch Total. *Gate time* is not used.

Three values are tracked and can be separately displayed by pressing the *RESET* key: Item #1, the Batch Total; Item #2, the Grand Total of all batches or Number of Batches (selectable during setup); and Item #3, the Fill Rate.

- **Item #1, Batch Total**, is the total for that batch. It may be configured to count up from 0 to a preset, or to count down from a preset to 0. The preset value is placed in *SETPT1*. *SCALE1* is positive whether counting up or down.
- **Item #2, Grand Total**, is the sum of previous Batch Totals and the current Batch Total. It can overflow to exponential format.
- **Item #2 (alternate), Number of Batches**, is the current count of batches. *SCALE1* does not apply. *dECPT1* is set to 1.
- **Item #3, Fill Rate**, is calculated with a fixed 20 ms (or 1 cycle min) *gate time*. It may be displayed as Item #3.

### PERIOD MODES

- **PERIOD A ONLY (A\_OnLy)** displays period of Channel A as Item #1.
- **PERIOD A B (A\_\_b\_\_)** displays period of Ch A as Item #1 and of Ch B as Item #2.
- **PERIODS A+B, A-B, AxB, A-B, A/B** (Extended counter) display arithmetic combinations of Periods A and B as Item #1, Period A as Item #2, and Period B as Item #3.

### TIMING MODES

#### STOPWATCH TIMING, “ON” TIME OF A MACHINE WITH 0.00 HOUR RESOLUTION

Dig. No.	S	1	2	3	4	5	6						
InPut		S	t	o	P		t	A	t	o	b		
SEtuP			1	0	1	1	0						
ConFiG				4	0	0	0						
dSPyno						0	1						
GAtE t			0	0	0.	0	1						
SLOPE						1	0						
DecPt1		1	1	1	1.	1	1						
DecPt2		2	2	2	2	2	2.						
Lo In1		0	0	0	0	0	0						
Lo rd1		0	0	0	0.	0	0						
Hi In1		0	0	3	6	0	0						
Hi rd1		0	0	0	1.	0	0						
Lo In2		0	0	0	0	0	0						
Lo rd2		0	0	0	0	0	0						
Hi In2		0	0	3	6	0	0						
Hi rd2		0	0	0	0	0	1						
CALib	-		0	0	0	0	0	Do Not Change Calib					

**Application:** Display daily “on” time of a machine in hours with 2 decimals. For machine maintenance, also track accumulated hours since last reset.

**Solution:** Tie a relay across the AC input to the machine so that the relay closes to ground when power is applied. Apply the relay output across both the A & B inputs so that the voltage is 5V when the contacts are open and 0V when they are closed. Set Input to “Stopwatch A to B.” Select negative trigger slope for A and positive for B. Under Config, set Display Mode to sec. Set Gate Time to 0.01 sec. Select the coordinates of 2 points scaling method for Item #1 (daily time) and Item #1 (accumulated time). For Item #1, set DecPt1 to 2 places, set Hi In1 to 3600 (sec) and Hi Rd1 to 1.00 (hrs). For Item #2, set DecPt2 to 0 places, set Hi In2 to 3600 and Hi Rd2 to 1 (hr).

## STOPWATCH TIMING, CLOSING TIME OF A RELAY TO 0.001 MSEC RESOLUTION

Dig. No.	S	1	2	3	4	5	6								
InPut		S	t	o	P		t	A		t	o		b		
SEtuP			1	0	1	1	0								
ConFiG				4	0	0	0								
dSPyno						0	1								
GAtE t			0	0	0.	0	1								
SLOPE						0	0								
DecPt1		1	1	1.	1	1	1								
DecPt2		2	2	2	2	2	2.								
Lo In1		0	0	0	0	0	0								
Lo rd1		0	0	0.	0	0	0								
Hi In1		1.	0	0	0	0	0								
Hi rd1		9	9	9.	9	9	9								
Lo In2		0	0	0	0	0	0								
Lo rd2		0	0	0	0	0	0								
Hi In2		0	0	0	0	0	0								
Hi rd2		0	0	0	0	0	0								
CALib	-		0	0	1	0	0	Do Not Change Calib							

**Application:** Measure the closing time of a relay in msec to 0.001 msec resolution.

**Solution:** To close the relay, apply the same positive voltage to the relay coil and to meter Channel A. Wire the relay so that 0V is applied across Channel B when the contacts are closed. Set Input to “Stopwatch A to B.” Select a positive trigger slope for A and a negative trigger slope for B. Under Config, set Display Mode to sec. Set Gate Time to 0.01 sec. Select the coordinates of 2 points scaling method for Item #1. Set DecPt1 to 3 places. Set Hi In1 to 1.00000 (sec) and Hi Rd1 to 999.999 (msec). Ignore Item #2, which is not used.

- TIME INTERVAL A TO B (A\_to\_b)** measures time between periodic inputs on Channels A and B. Timing starts when a pulse is applied to Channel A (positive edge if slope A is 0, negative edge if slope A is 1), and ends when a pulse is applied to Channel B (positive edge if slope B is 0, negative edge if slope B is 1). Pulse width may be measured by tying inputs A and B together and selecting a positive or negative edge to start (Slope A) and the opposite polarity edge to stop (Slope B). If multiple start and stop pulses occur during the *gate time*, the displayed value is the average of pulse widths. The value is updated at the end of each *gate time*. With a scale factor of 1, one count is one microsecond.
- INVERSE TIME INTERVAL ( \_\_1/Ab)** (Extended counter)  
 Takes the inverse of time interval for a reading in /second. For example, if the average time interval for object to travel from point A to point B is 5 seconds, the inverse time interval would be 0.2/sec. For the average speed of the objects, simply apply a scale factor equal to the distance separating the two points, such as 7 (inches). Speed would then be displayed as  $7 \times 0.2 = 1.4$  (inches/sec). For a 6-digit reading, apply a scale multiplier of 10,000 and move the decimal point.
- STOPWATCH A TO A (A\_to\_A)** measures time between the same positive (or negative) edge of start and stop pulses applied to Channel A. Single event times may be displayed as Item #1 in decimal seconds, minutes or hours, or in HH:MM:SS clock format. Time is reset to 0 when a new start pulse occurs. Accumulated total time may be displayed as Item #2. With a scale factor of 1, one count is one microsecond.
- STOPWATCH A TO B (A\_to\_B)** measures time between a start pulse on Channel A and a stop pulse on Channel B. Timing is the same as for A to A, except that positive or negative edges may be selected separately for Channels A and B. This allows the pulse width measurement of single pulses by tying Channels A and B together. One slope is selected to start timing, and the opposite slope to stop timing.

- **INVERSE STOPWATCH TIME A TO A & A TO B ( $\frac{1}{AA}$  &  $\frac{1}{AB}$ )** (Extended counter)  
 Takes the inverse of stopwatch time for a reading in /second. For example, if the travel time for an object to travel from point A to point B is 5 seconds, the inverse stopwatch time interval would be 0.2/sec. For the speed of that object, simply multiply by a scale factor equal to the distance separating the two points, such as 7 (inches). Speed would then be displayed as  $7 \times 0.2 = 1.4$  (inches/sec). For a 6-digit reading, apply a scale multiplier of 10,000 and move the decimal point.

**DUTY CYCLE MODE (duty\_C)** (Extended counter)

Measures ON or OFF period of periodic square waves as a percentage of total period over a *gate time* which is selectable from 10 ms to 199.99 s. The same signal is applied to Channels A and B. ON or OFF time is measured between positive and negative edges of the signal, with averaging over multiple integral periods over the selected gate time. Apply a scale factor of 1 for readings in percent. Apply a 10 or 100 multiplier and move the decimal point by 1 or 2 positions for 0.1% or 0.01% resolution.

**PHASE ANGLE MODE (PHASE)** (Extended counter)

Measures the phase relationship in degrees between two signals with the same period over a *gate time* which is selectable from 10 ms to 199.99 s, with averaging over multiple integral periods over the selected gate time. The two signals are applied to Channels A and B. For best accuracy, both signals should have the same amplitude. The amplitude of sinusoidal signals should be larger than 1V, and the trigger level should be set at 12 mV (no jumper at A3 or B3, jumper a at A2 and B2).

**PHASE ANGLE MEASUREMENT TO 0.01° RESOLUTION**

Dig. No.	S	1	2	3	4	5	6
InPut			P	H	A	S	E
SEtuP		0	0	1	0	0	
ConFIG				1	1	0	0
dSPyno						0	1
GAtE t			0	0	0.	2	2
ti Out			0	0	1.	0	0
bAtCH			0	0	0	0	0
FILtEr			0	0	1	0	5
SLOPE						0	0
DecPt1		1	1	1	1.	1	1
Lo ln1		0	0	0	0	0	0
Lo rd1		0	0	0	0.	0	0
Hi ln1		1.	0	0	0	0	0
Hi rd1		0	0	0	1.	0	0
rESoLn							1
CALib	-		0	0	0	0	0

Do Not Change Calib

**Application:** Measure phase angle difference to 0.01° resolution between two AC signals centered around 0°.

**Solution:** Use an Extended counter, as required for phase angle measurement. Jumper the signal conditioner for maximum sensitivity to catch zero voltage crossings and minimize the effects of amplitude jitter. Apply one AC signal to Channel A and one to Channel B. Set Input to "PHASE +/- 180°." The display will be in degrees. Set a gate time of 0.22 sec for 4 display updates per sec. Set both trigger slopes to positive. Set two decimal places. Select the coordinates of 2 points scaling method. Set Hi ln1 to 1.00000 (degrees) and Hi Rd1 to 1.00 (degrees). As an alternative, select the scale and offset scaling method. Then simply select a scale value of 1.00000 and a multiplier of 100.

## DUTY CYCLE MEASUREMENT TO 0.01% RESOLUTION



Dig. No.	S	1	2	3	4	5	6						
InPut		d	u	t	y		C	A		t	o		b
SEtuP			0	0	1	0	0						
ConFIG				1	1	0	0						
dSPyno						0	1						
GAtEt			1	0	0.	0	0						
ti Out			1	9	9.	9	9						
FILtEr			0	0	1	0	5						
SLOPE						0	0						
DecPt1		1	1	1	1.	1	1						
Lo In1		0	0	0	0	0	0						
Lo rd1		0	0	0	0.	0	0						
Hi In1		1.	0	0	0	0	0						
Hi rd1		0	0	0	1.	0	0						
CALib	-		0	0	0	0	0	Do Not Change Calib					



**Application:** Measure “on” period of periodic pulses as a % of total period with .01% resolution over a time interval of 100 sec.

**Solution:** Phase angle measurement requires the Extended counter. Apply the same signal to Channels A & B. Set Input to “Duty Cycle (A to B) / A.” The native counts will be in percent. For a positive “on” pulse, set trigger slope to positive for A and negative for B. Select the coordinates of 2 points scaling method. Set Hi In1 to 1.00000 (percent) and Hi Rd1 to 1.00 (percent). As an alternative, select the scale and offset scaling method. Then simply select a scale value of 1.00000 and a multiplier of 100.



## SETUP OF COUNTERS WITH DUAL CHANNEL PULSE OR AC SIGNAL CONDITIONER

If the **MENU**  key does not work, see Section 9 “Enabling & Locking Out Menu Items.” Menus are dynamic. Menu items will only appear if appropriate for previously made menu selections. For example, Batch menu items will only appear if “Batch” was selected under “Rate.” Extended counter items will only appear if “Extended” was selected under “Config.”

 <b>MENU</b> Press Menu	 <b>PEAK</b> Press Digit Select Key	 <b>RESET</b> Press Value Select Key
<b>InPut</b> Input	<b>rAtE</b> Rate modes	<b>Basic</b>
		<b>A_b</b> Rate for Channel A (Item #1). Rate for Channel B (Item #2).
		<b>A_OnLy</b> Rate for Channel A only (Item #1).
		<b>bAtCH</b> Batch control mode. Batch total (Item #1). Grand total or number of batches (Item #2). Fill rate (Item #3).
		<b>A_Atot</b> Rate for Channel A (Item #1). Total for Channel A (Item #2).
		<b>A_btot</b> Rate for Channel A (Item #1). Total for Channel B (Item #2).
		<b>A + b</b> Sum of rates A & B (Item #1). Rate A (Item #2). Rate B (Item #3).
		<b>A - b</b> Difference of rates A and B (Item #1). Rate A (Item #2). Rate B (Item #3).
		<b>A . b</b> Product of rates A and B (Item #1). Rate A (Item #2). Rate B (Item #3).
		<b>A / b</b> Rate A divided by rate B (Item #1). Rate A (Item #2). Rate B (Item #3).
		<b>A/b-1</b> Draw, rate A / rate B - 1 (Item #1). Rate A (Item #2). Rate B (Item #3).
		<b>Extended meter only</b>
		<b>Period</b> Period modes
		<b>Basic</b>
<b>A_b</b> Period Channel A (Item #1). Period for Channel B (Item #2).		
<b>A_OnLy</b> Period for Channel A only (Item #1).		
<b>Extended meter only</b>		
<b>A + b</b> Sum of periods A and B (Item #1). Period A (Item #2). Period B (Item #3).		
<b>A - b</b> Difference of periods A and B (Item #1). Period A (Item #2). Period B (Item #3).		
<b>A . b</b> Product of periods A and B (Item #1). Period A (Item #2). Period B (Item #3).		
<b>A / b</b> Ratio, period A divided by period B (Item #1). Period A (Item #2). Period B (Item #3).		



 <b>MENU</b> Press Menu	 <b>PEAK</b> Press Digit Select Key	 <b>RESET</b> Press Value Select Key		
<b>InPut</b> (continued)	<b>totAL</b> Total modes	Basic	<b>A b</b> Total for Channel A (Item #1). Total for Channel B (Item #2).	
			<b>A_OnLy</b> Total for Channel A only (Item #1).	
		Extended meter only	<b>A-b_Ud</b> Running total (Item #1) of counts on Channel A minus counts on Channel B.	
			<b>burSt</b> Count of bursts (Item #1). Burst frequency (Item #2).	
			<b>b_ArAt</b> Total for Channel B (Item #1). Rate for Channel A (Item #2)	
			<b>A bU/d</b> Total for Channel A (Item #1) with up/down control via Channel B.	
			<b>A b InH</b> Total for Channel A (Item #1) with count inhibit control via Channel B.	
			<b>A + b</b> Sum of totals A and B (Item #1). Total A (item #2). Total B (Item #3).	
			<b>A - b</b> Difference of totals A and B (Item #1). Total A (item #2). Total B (Item #3).	
			<b>A . b</b> Product of totals A and B (Item #1). Total A (item #2). Total B (Item #3).	
			<b>A / b</b> Ratio of totals A and B (Item #1). Total A (item #2). Total B (Item #3).	
		Basic	<b>ti Int</b> Time interval mode	<b>A to b</b> Time interval (Item #1) for periodic events with pulse signals applied to Channels A & B.
			Ext.	<b>1/Ab</b> Inverse of time interval (/sec) (Item #1) for periodic events with pulse signals applied to A & B.
		<b>StoP_t</b> Stopwatch modes	Basic	<b>A to A</b> Single event time (Item #1) between pulses on Channel A, or accumulated total time (Item #2).
				<b>A to b</b> Single event time (Item #1) with pulses on Channels A &B, or accumulated total time (Item #2).
Extended	<b>1/AA</b> Inverse of stopwatch time (/sec) (Item #1) for single events with pulse signals applied to A & A.			
	<b>1/Ab</b> Inverse of stopwatch time (/sec) (Item #1) for single events with pulse signals applied to A & B.			



 <b>Press Menu</b>	 <b>Press Digit Select Key</b>	 <b>Press Value Select Key</b>
<b>InPut</b> (continued)	<b>PHASE</b> Phase angle modes	<b>Extended</b> <b>0-360</b> Span from 0° to 360°. Select for phase angles centered around 180° (Item #1). <b>-180+</b> Span from -180° to +180°. Select for phase angles centered around 0° (Item #1).
	<b>duty_C</b> Duty cycle mode	<b>Ext.</b> <b>A to b</b> On or Off period of square waves as a percentage of total period (Item #1).
<b>SEtuP</b> Setup	<b>00000</b> Stored totals	<b>0</b> Zero totals at power-on. <b>1</b> Restore totals at power-on.
	<b>00000</b> Leading zeros	<b>0</b> Blank leading zeros. <b>1</b> Display leading zeros.
	<b>00000</b> Scaling method 1	<b>0</b> Input scale factor 1 and offset 1. <b>1</b> Use coordinates of 2 points method.
	<b>00000</b> Scaling method 2	<b>0</b> Input scale factor 2 and offset 2. <b>1</b> Use coordinates of 2 points method.
	<b>00000</b> Operation of rear connector control inputs 1 & 2. <b>True</b> = logic 1 (0V or tied to digital ground). <b>False</b> = 0 (5V or open).	<b>0</b> 1 = Meter Reset*, 2 = Function Reset* <b>1</b> 1 = Meter Reset*, 2 = Meter Hold* <b>2</b> 1 = Meter Reset*, 2 = Peak or Valley Display* <b>3</b> 1 = Meter Reset*, 2 = External Gate* <b>4</b> 1 = Function Reset*, 2 = Meter Hold* <b>5</b> 1 = Valley Only Display, 2 = Peak Only Display <b>6</b> 1 = Function Reset*, 2 = External Gate* <b>7</b> 1 = Meter Hold*, Peak or Valley Display* <b>8</b> 1 = Meter Hold*, 2 = External Gate* <b>9</b> 1 = Peak or Valley Display, 2 = External Gate* <b>A</b> 1 = Meter Reset*, 2 = Display Blank* <b>B</b> 1 = Function Reset*, 2 = Display Blank* <b>C</b> 1 = Meter Hold*, 2 = Display Blank* <b>D</b> 1 = Peak or Valley Display, 2 = Display Blank* <b>E</b> 1 = Display Blank, 2 = External Gate* <b>F</b> 1 = Display Item #2*, 2 = Display Item #3*  ----- With neither 1 nor 2, or both 1 & 2, display Item #1. 1 & 2 both at 0V for selections <b>5</b> , <b>7</b> , <b>D</b> = Function Reset* (erases all totals). 1 & 2 both at 0V for selections <b>0</b> , <b>1</b> , <b>2</b> , <b>3</b> , <b>4</b> , <b>6</b> , <b>8</b> , <b>A</b> , <b>B</b> , <b>C</b> , <b>E</b> = Meter Reset* (can restore totals).

<b>MENU</b> Press Menu	<b>PEAK</b> Press Digit Select Key	<b>RESET</b> Press Value Select Key
<b>ConFIG</b> Configuration	<b>0000</b> Display mode	<b>0</b> Normal, overload to exponential format <b>1</b> Normal, overload to 999999 <b>2</b> 1 right-hand dummy zero <b>3</b> 2 right-hand dummy zeros <b>4</b> Time display in seconds <b>5</b> Time display in HH.MM.SS format <b>6</b> Remote display (H, K, L commands) <b>7</b> Single-value remote display <b>8</b> Show 1 <sup>st</sup> string value, slaved to another meter <b>9</b> Show 2 <sup>nd</sup> string value, slaved to another meter <b>A</b> Show 3 <sup>rd</sup> string value, slaved to another meter <b>B</b> Show 4 <sup>th</sup> string value, slaved to another meter <b>C</b> Custom Start, Stop, Skip, Show
	<b>0000</b> Counter mode	<b>0</b> Basic counter <b>1</b> Extended counter <b>2</b> Extended counter, custom curve linearization
	<b>0000</b> Square root	<b>0</b> Linear rate input. <b>1</b> Square root rate input.
	<b>0000</b> Not applicable	<b>0</b> Set to 0.
<b>dSPyno</b> Display #	<b>01</b> PEAK key action	<b>0</b> Display Peak <b>1</b> Display Valley <b>2</b> Peak (1 <sup>st</sup> push), Valley (2 <sup>nd</sup> push)
	<b>01</b> Item to display after Meter Reset*	<b>1</b> Item #1* <b>2</b> Item #2* <b>3</b> Item #3*
<b>GAtE t</b> Gate time*	<b>000.00</b> <b>000.00</b> <b>000.00</b> <b>000.00</b> <b>000.00</b> Select digit to flash.	Select <b>0</b> thru <b>9</b> for flashing digit to set gate time* in seconds. Decimal point location is fixed for 10 ms resolution.
<b>ti_Out</b> Time-out*	<b>000.00</b> <b>000.00</b> <b>000.00</b> <b>000.00</b> <b>000.00</b> Select digit to flash.	Select <b>0</b> thru <b>9</b> for flashing digit to set time-out* in seconds. Decimal point location is fixed for 10 ms resolution.
<b>bAtCH</b> Batch setup	<b>00000</b> Handling of overshoot count at end of batch.	<b>0</b> Do not count extra pulses after Preset. Add Preset values to Grand Total. <b>1</b> Count all pulses. Add Preset values to Grand Total. <b>2</b> Do not count extra pulses after Preset. Add actual Batch Totals to Grand Total. <b>3</b> Count extra pulses after Preset. Add actual Batch Totals to Grand Total.
	<b>00000</b> Count direction	<b>0</b> Reset batch to 0 and count up to Setpoint 1. <b>1</b> Reset batch to Setpoint 1 and count down.
	<b>00000</b> Batch triggering	<b>0</b> Use internal gate time as delay between batches <b>1</b> Use External Input B to trigger each new batch.

<b>MENU</b> Press Menu	<b>PEAK</b> Press Digit Select Key	<b>RESET</b> Press Value Select Key
<b>bAtCH</b> (continued)	<b>_00000</b> Definition of Item #2	<b>0</b> Make Item #2 the Grand Total of all batches. <b>1</b> Make Item #2 the Total Number of batches.
	<b>_00000</b> Action after Meter Reset	<b>0</b> Display "rEAdy." <b>RESET</b> key starts batching. <b>1</b> Start batching upon Meter Reset.
<b>FiLteR</b> Filtering	<b>_00000</b> Filter type	<b>0</b> Adaptive moving average filter. Restarts filter for high actual changes in signal. <b>1</b> Conventional moving average filter without reset.
	<b>_00000</b> Peak & Valley filtering	<b>0</b> Peak* or Valley* value from unfiltered signal. <b>1</b> Peak* or Valley* value from filtered signal.
	<b>_00000</b> Display filtering	<b>0</b> Display value of unfiltered signal. <b>1</b> Display value of filtered signal.
	<b>_00000</b> Adaptive filter threshold	<b>0</b> Set adaptive filter for normal noise. <b>1</b> Set adaptive filter for presence of high transients.
	<b>_00000</b> Filter time constant	<b>0</b> No filter <b>1</b> 0.1 sec <b>2</b> 0.2 sec <b>3</b> 0.4 sec <b>4</b> 0.8 sec <b>5</b> 1.6 sec <b>6</b> 3.2 sec <b>7</b> 6.4 sec
<b>SLOPE</b> Triggering	<b>_00</b> Trigger slope, Channel A	<b>0</b> Positive slope <b>1</b> Negative slope
	<b>_00</b> Trigger slope, Channel B	<b>0</b> Positive slope <b>1</b> Negative slope
<b>dEC.Pt1</b> Decimal pt1	<b>1_11111</b> Decimal point flashes.	<b>1_11111</b> <b>11_11111</b> <b>111_111</b> <b>1111_11</b> <b>11111_1</b> <b>111111_</b> Press <b>▲</b> to shift the decimal point.
<b>dEC.Pt2</b> Decimal pt2	<b>2_22222</b> Decimal point flashes.	<b>2_22222</b> <b>22_22222</b> <b>222_222</b> <b>2222_22</b> <b>22222_2</b> <b>222222_</b> Press <b>▲</b> to shift the decimal point.
Scale and Offset scaling method if selected under <b>SEtuP</b>		
<b>SCALE1</b> Scale Factor 1	<b>0.00000</b> <b>0.00000</b> <b>0.00000</b> <b>0.00000</b> <b>0.00000</b> <b>0.00000</b> Select digit to flash for Scale Value. When right digit flashes, press <b>▶</b> one more time for the Scale Multiplier.	Select <b>9</b> thru <b>9</b> for flashing first digit and <b>0</b> thru <b>9</b> for other flashing digits. This will set the Scale Value* from -9.99999 to 9.99999 with a fixed decimal point. Then press <b>▲</b> to select a value from <b>0.00001</b> to <b>100000</b> in decade steps for the Scale Multiplier. Scale Factor = Scale Value x Scale Multiplier.
<b>OFFSt1</b> Offset 1	<b>000000</b> <b>000000</b> <b>000000</b> <b>000000</b> <b>000000</b> <b>000000</b> Select digit to flash.	Select <b>9</b> thru <b>9</b> for flashing first digit and <b>0</b> thru <b>9</b> for other flashing digits. Use <b>dEC.Pt1</b> to set the decimal point.
<b>SCALE2</b>	Scale Factor 2. Same setup process as for Scale Factor 1.	
<b>OFFSt2</b>	Offset 2. Same setup process as for Offset 1.	

 <b>MENU</b> Press Menu	 <b>PEAK</b> Press Digit Select Key	 <b>RESET</b> Press Value Select Key
Coordinates of 2 points scaling method if selected under <b>SEtUP</b>		
<b>Lo_In1</b> Low signal input 1.	<u>000000</u> <u>000000</u> <u>000000</u> <u>000000</u> <u>000000</u> <u>000000</u> Select digit to flash.	Select <b>9</b> thru <b>9</b> for flashing first digit and <b>0</b> thru <b>9</b> for other flashing digits. Move decimal point location when flashing.
<b>Lo_rd1</b> Reading at Lo In1.	<u>000000</u> <u>000000</u> <u>000000</u> <u>000000</u> <u>000000</u> <u>000000</u> Select digit to flash.	Select <b>9</b> thru <b>9</b> for flashing first digit and <b>0</b> thru <b>9</b> for other flashing digits. Decimal point is fixed by <b>dEC.Pt1</b> .
<b>Hi_In1</b> High signal input 1.	<u>000000</u> <u>000000</u> <u>000000</u> <u>000000</u> <u>000000</u> <u>000000</u> Select digit to flash.	Select <b>9</b> thru <b>9</b> for flashing first digit and <b>0</b> thru <b>9</b> for other flashing digits. Move decimal point location when flashing.
<b>Hi_rd1</b> Reading at Hi In1.	<u>000000</u> <u>000000</u> <u>000000</u> <u>000000</u> <u>000000</u> <u>000000</u> Select digit to flash.	Select <b>9</b> thru <b>9</b> for flashing first digit and <b>0</b> thru <b>9</b> for other flashing digits. Decimal point is fixed by <b>dEC.Pt1</b> .
<b>Lo_In2</b> Low signal input 2.	<u>000000</u> <u>000000</u> <u>000000</u> <u>000000</u> <u>000000</u> <u>000000</u> Select digit to flash.	Select <b>9</b> thru <b>9</b> for flashing first digit and <b>0</b> thru <b>9</b> for other flashing digits. Move decimal point location when flashing.
<b>Lo_rd</b> Reading at Lo In2.	<u>000000</u> <u>000000</u> <u>000000</u> <u>000000</u> <u>000000</u> <u>000000</u> Select digit to flash.	Select <b>9</b> thru <b>9</b> for flashing first digit and <b>0</b> thru <b>9</b> for other flashing digits. Decimal point is fixed by <b>dEC.Pt1</b> .
<b>Hi_In2</b> High signal input 1.	<u>000000</u> <u>000000</u> <u>000000</u> <u>000000</u> <u>000000</u> <u>000000</u> Select digit to flash.	Select <b>9</b> thru <b>9</b> for flashing first digit and <b>0</b> thru <b>9</b> for other flashing digits. Move decimal point location when flashing.
<b>Hi_rd2</b> Reading at Hi In1.	<u>000000</u> <u>000000</u> <u>000000</u> <u>000000</u> <u>000000</u> <u>000000</u> Select digit to flash.	Select <b>9</b> thru <b>9</b> for flashing first digit and <b>0</b> thru <b>9</b> for other flashing digits. Decimal point is fixed by <b>dEC.Pt1</b> .
Preset function. Displayed for Total modes <b>A-b_Ud</b> or <b>A bU/d</b>		
<b>PrESet</b> Preset*	<u>000000</u> <u>000000</u> <u>000000</u> <u>000000</u> <u>000000</u> <u>000000</u> Select digit to flash.	Select <b>9</b> thru <b>9</b> for flashing first digit and <b>0</b> thru <b>9</b> for other flashing digits. <b>dEC.Pt1</b> is used. When the meter counts up and reaches the Preset, it reverts to Offset1. When the meter counts down and reaches Offset1, it reverts to Preset. Set to 0 for no Preset.
Special curve offset for square root or custom curve linearization if selected under <b>ConFIG</b>		
<b>rd0_In</b>	<u>000000</u> <u>000000</u> <u>000000</u> <u>000000</u> <u>000000</u> <u>000000</u> Select digit to flash.	Select <b>9</b> thru <b>9</b> for flashing first digit and <b>0</b> thru <b>9</b> for other flashing digits. Decimal point is fixed by <b>dEC.Pt1</b> .

Scale multiplier for combinations of two channels (e.g., AxB, A/B) if selected under <b>InPut</b>		
<b>rESoLn</b> Resolution	Flashing 6-digit number in decade steps from <b>0.00001</b> to <b>100000</b>	Press <b>▲</b> to select. This is a multiplier <b>R</b> to avoid overflow or underflow of arithmetic combinations of Channels A and B.
Quartz crystal time base calibration		
<b>CALib</b>	Time base calibration.	Do not change. See Calibration section of manual.
Option dependent menu items		
<b>Source</b> <b>AL_Set</b> <b>dEUn1b</b> <b>dEUn2b</b> <b>dEUn1h</b> <b>dEUn2h</b> Menu items related to <b>alarms</b> . These will only appear if a relay board is detected. If so, please see Section 13.		
<b>An_Set</b> <b>An_Lo</b> <b>An_Hi</b> Menu items related to <b>analog output</b> . These will only appear if an analog output board is detected. If so, please see Section 14.		
<b>Ser_1</b> <b>Ser_2</b> <b>Ser_3</b> <b>Ser_4</b> Menu items related to <b>serial communications</b> . These will only appear if an RS232 or RS485 I/O board is detected. If so, please see Section 15.		
Menu lockout items		
<b>Loc_1</b> <b>Loc_2</b> <b>Loc_3</b> <b>Loc_4</b> Menu items used to enable or lock out (hide) other menu items. <b>Loc</b> menu items may be locked out by a hardware jumper. Please see Section 9.		

\* See Glossary for explanation of item.

## 11. PROCESS RECEIVER & TOTALIZER SIGNAL CONDITIONER (VF)

This signal conditioner board converts 0-1 mA, 4-20 mA or 0-10 V analog process signals to a frequency signal, which is then read by the counter main board and processed mathematically for display of rate, total (time x rate), time based on rate, or batch control. The board needs to be configured via jumpers for the input signal range. The meter software recognizes the board and brings up the applicable menu items for it.

Please see further manual pages for the following features: relay output (49), analog output (51), serial communications (52), parallel BCD output (55), and transducer excitation output (56).

### JUMPER SETTINGS

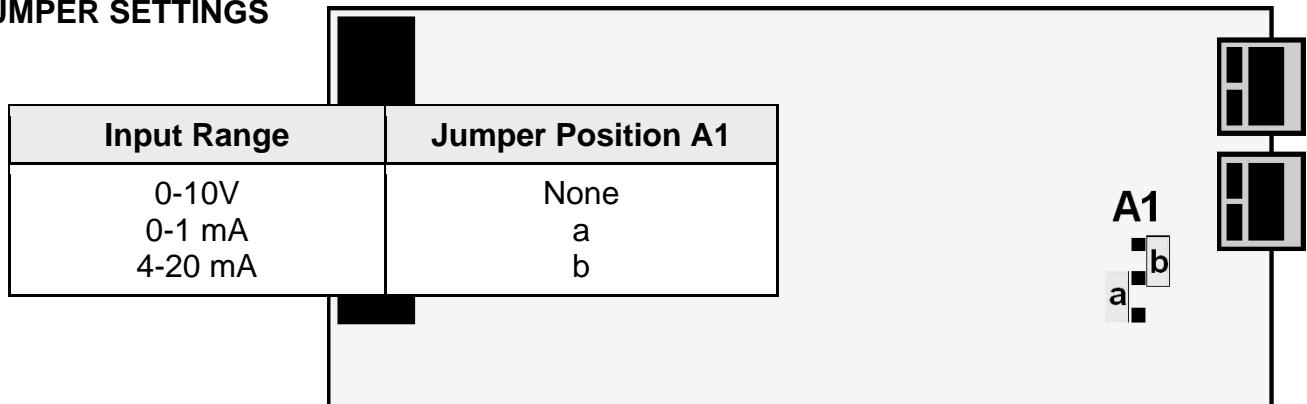

### OPERATING MODES

#### RATE FROM A 4-20 mA OUTPUT FLOW METER

Dig. No.	S	1	2	3	4	5	6								
InPut		U	F	4	-	2	0	A		O	n	L	y		
SEtuP			0	0	1		0								
ConFIG				1	0	0	0								
dSPyno						0	1								
GATe t			0	0	0.	2	2								
FILtEr			0	0	1	0	5								
DecPt1		1	1	1.	1	1	1								
Lo In1		0	4.	0	0	0	0								
Lo rd1		0	0	0.	0	0	0								
Hi In1		2	0.	0	0	0	0								
Hi rd1		0	0	5.	8	2	0								
CALib	-		0	0	0	0	0	Do Not Change Calib							

**Application:** Display rate in GPM with 3 decimal places from a 4-20 mA flow meter where 4 mA = 0 GPM and 20 mA = 5.820 GPM.

**Solution:** Set Input to “VF420 A only.” Under Setup, select the coordinates of 2 points scaling method. Under Config, select a display of 999999 and filtering. Set the decimal point to 3 places. For scaling, set Hi In1 to 20.0000 and Hi Rd1 to 5.820. Set Gate Time to 0.22 sec, which will provide noise averaging at a display update rate of 4/sec. Also set a 1.6 sec adaptive moving average filter, which will process the equivalent of 6 readings.

#### RATE MODE (Basic Counter)

**Rate A** accepts 0-1 mA, 4-20 mA or 0-10 V analog process signals for a process display scaled to engineering units. Scaling is normally done using the coordinates of 2 points method, where low and high input signals and the corresponding desired low and high displayed values are entered. Scaling can also be done by entering scale and offset directly.

With Scale1 set to 1 and Offset1 set to 0, the full analog input range is displayed as 0-100000. Measurements are averaged over a gate time, which is programmable from 10 ms to 199.99 sec. Selecting a long gate time provides a slower display update rate but superior noise filtering. Moving average filtering is also available. Square root extraction is selectable for use with differential pressure flow transducers. Custom curve linearization is available with the Extended counter.

### RATE & TOTAL MODE (Basic Counter)

#### TOTAL FROM A 4-20 mA OUTPUT FLOW METER

**Application:** Display Total from a 4-20 mA flow meter where 4 mA = 0 and 20 mA = 5.820 GPM.

**Solution:** Use Extended counter. Set Input to "VF420 A A Total," which displays Rate as Item #1 & Total as Item #2. Under dSPyno, select Item #2 to be displayed after meter reset. Set Gate Time to 0.1 sec to provide fast display updates with noise averaging. Set DecPt1 to 3 places for Rate and DecPt2 to 2 places for Total. Under Setup, select the coordinates of 2 points scaling method for Rate. Set Hi In1 to 20.0000 and Hi Rd1 to 5.820. You will need to use scale & offset to scale Total. Enter 1.66667 for Scale2 and a multiplier of 0.001. That is because totalizing sums rate readings every second. Since our rate is in units per minute, we have to divide by 60, then multiply by 0.1 for two decimal places. You may also enter a Cutoff such as 0.010 GPM, below which zero offset errors and negative values will not be totalized.

Dig. No.	S	1	2	3	4	5	6							
InPut		U	F	4	-	2	0	A	A	t	o	t		
SEtuP			0	0	1		0							
ConFiG				1	1	0	0							
dSPyno						0	1							
CutoFF			0	0.	0	1	0							
GAtEt			0	0	0.	1	0							
FILtEr			0	0	1	0	3							
DecPt1		1	1	1.	1	1	1							
DecPt2		2	2	2	2.	2	2							
Lo In1		0	4.	0	0	0	0							
Lo rd1		0	0	0.	0	0	0							
Hi In1		2	0.	0	0	0	0							
Hi rd1		0	0	5.	8	2	0							
SCALE2		1.	6	6	6	6	7	0.	0	0	0	1		
OFFSt2		0	0	0	0.	0	0							
CALib	-		0	0	0	0	0	Do Not Change Calib						

**Rate A, Total A** allows rate to be displayed as Item #1 and total as Item #2. Scale2 and Offset2 apply to total. Total is calculated as the product of displayed rate and time in seconds. Since rate may be displayed in units per second, units per minute, units per hour or other units, the total must be scaled appropriately. If rate is in units per minute, multiply the total by 1/60. This is achieved by setting Scale2 to a scale factor of 1.66666 and a multiplier of 0.01. If rate is in units per hour, multiply the total by 1/3600. This is achieved by setting Scale2 to a scale factor of 2.77778 and a multiplier of 0.0001. If square root extraction or custom curve linearization (available with Extended counter) have been selected, totalizing will be of the linearized rate readings.

### BATCH CONTROL MODE (\_bAtCH) (Extended Counter)

**Batch control** uses the meter with a dual relay controller board to control repetitive fill operations. Relay #1 (or Setpoint #1) is used as the batch relay. Relay #2 (or Setpoint #2) can be assigned to another limit, such as pre-warn to slow filling near the setpoint, end-of-process, or rate alarm. The same signal is applied to Channels A and B.

- **In batch control mode without external resets**, the meter waits until the *RESET* key is pushed at the end of every cycle. It then energizes Relay #1 and displays the changing Batch Total. When the preset value is reached, Relay #1 de-energizes for the duration of

the gate time setting. Relay #1 then re-energizes, the Batch Total resets, and the fill cycle repeats.

- **In batch control mode with external resets**, the meter waits at the end of every cycle until an external *Function Reset* input is grounded for a minimum of 3.33 ms. This starts a new fill cycle by energizing Relay #1 and resetting the Batch Total. *Gate time* is not used.

Three values are tracked and can be separately displayed by pressing the *RESET* key: Item #1, the Batch Total; Item #2, the Grand Total of all batches or Number of Batches (selectable during setup); and Item #3, the Fill Rate.

- **Item #1, Batch Total**, is the total of input pulses for that batch. It may be configured to count up from 0 to a preset, or to count down from a preset to 0. The preset value is placed in *ALARM1*. *SCALE1* is positive whether counting up or down.
- **Item #2, Grand Total**, is the sum of previous Batch Totals and the current Batch Total. It can overflow to exponential format.
- **Item #2 (alternate), Number of Batches**, is the current count of batches. *SCALE1* does not apply. *dECPt1* is set to 1.
- **Item #3, Fill Rate**, is calculated with a fixed 20 ms (or 1 cycle min) *gate time*. It may be displayed as Item #3.

### BATCH CONTROL WITH A 4-20 mA OUTPUT FLOW METER

Dig. No.	S	1	2	3	4	5	6
InPut				r	A	t	E
SEtUP			1	0	0	1	0
ConFiG				1	1	0	0
dSPyno						0	1
CutoFF	0	0	0	0	0.		
GAtEt			0	2	0.	0	0
bAtCH			1	0	0	1	0
FILtEr			0	0	1	0	5
SLOPE						0	0
DecPt1		1	1	1	1.	1	1
DecPt2		2	2	2	2.	2	2
SCALE1		1.	6	6	6	6	7
OFFSt1		0	0	5	5.	0	0
Lo In2		0	4.	0	0	0	0
Lo rd2		0	0	0	0.	0	0
Hi In2		2	0.	0	0	0	0
Hi rd2		0	0	3	9.	2	0
rESoLn							1
SourcE				1	1		
AL SET			0	0	2	4	0
dEU n1b		0	0	0	0.	0	0
dEU n2b		0	0	0	0.	0	0
CALib	-	0	0	0	0	0	0
Do Not Change Calib							
ALARM KEY	S	1	2	3	4	5	6
SETPT2	0	0	5	4.	0	0	

**Application:** Fill 55 gallon tanks. Use a 4-20 mA flow meter where 4 mA = 0 and 20 mA = 39.20 GPM. Slow down filling at 54 gallons. Cycle batches automatically with 20 sec between cycles. Display batch total & fill rate to 2 places. Also track number of batches.

**Solution:** Use an Extended counter with a dual relay output board. Set Input to "Rate Batch." Set Batch to count up to ALARM1, to use Gate Time as delay between batches, and to make Item #2 the number of batches. Set Gate Time to 20 sec. Set DecPt1 and DecPt 2 to two decimal places for Items #1 and #3 (Batch Total and Rate). Scale Item #3 (Rate) using the coordinates of 2 points method so that 20.0000 mA will be displayed as 39.20 GPM. Scale Item #1 (Batch Total) by entering a Scale1 of 1.66667 and a multiplier of 0.01. That is because totalizing sums readings in gallons every second. Since our rate is in GPM, we have to divide by 60. Enter an Offset1 of 55.00 to serve as the batch setpoint in gallons. Set Setpoint2 to 54.00 to activate Relay 2 to slow the fill rate.







## 1/RATE MODE (Extended Counter)



An example of 1/Rate is the time it takes an item takes to travel through an oven at a measured rate. Like Rate, 1/Rate can be scaled using Scale1 and Offset1. With no offset and Scale1 set to 1, Rate A for the full analog input range will be displayed as 0-100000, and 1/A will be displayed as 1000000/A. Both the A and 1/A readings are multiplied by Scale1 and offset by Offset1. With Scale1 set to 1, A is displayed as 10000, and 1/A is displayed as 100. With Scale1 set to 2, A is displayed as 20000, and 1/A is displayed as 200. If square root extraction is applied to rate, the rate display A is replaced by  $\sqrt{\_}$ , and 1/A is replaced by  $1/\sqrt{\_}$ . 1/A does not apply to custom curves.



Scaling may also be done by using the coordinates of 2 points method, which automatically calculates scale and offset for the displayed value when the low and high input signals and the corresponding desired low and high displayed values are entered.



## KEYSTROKES FOR SETUP

If the **MENU**  key does not work, see Section 9 “Enabling & Locking Out Menu Items.” Menus are dynamic. Menu items will only appear if appropriate for previously made menu selections. For example, Batch menu items will only appear if “Batch” was selected under “Rate.” Extended counter items will only appear if “Extended” was selected under “Config.”

 <b>Press Menu</b>	 <b>Press Digit Select Key</b>	 <b>Press Value Select Key</b>	
<b>InPut</b> Input	<b>VF0-10</b> 0-10V full-scale input	<b>Basic</b>	<b>A_OnLy</b> Rate for Channel A (Item #1).
			<b>A_Atot</b> Rate for Channel A (Item #1). Total for Channel A (Item #2).
	<b>VF4-20</b> 4-20 mA full-scale input	<b>Extended</b>	<b>bAtCH</b> Batch control mode. Batch total (Item #1). Grand total or number of batches (Item #2). Fill rate (Item #3).
			<b>1/A</b> 1/Rate for Channel A (Item #1).
<b>SEtuP</b> Setup	<b>000_0</b> Stored totals	<b>0</b> Zero totals at power-on. <b>1</b> Restore totals at power-on.	
	<b>000_0</b> Leading zeros	<b>0</b> Blank leading zeros. <b>1</b> Display leading zeros.	
	<b>000_0</b> Scale factor 1 setup	<b>0</b> Input scale factor 1 and offset 1. <b>1</b> Use coordinates of 2 points method.	
	<b>000_0</b> Operation of rear connector inputs 1 & 2. <b>True</b> = logic 1 (0V or tied to digital ground). <b>False</b> = 0 (5V or open).	<b>0</b> 1 = Meter Reset*, 2 = Function Reset*	
		<b>1</b> 1 = Meter Reset*, 2 = Meter Hold*	
<b>2</b> 1 = Meter Reset*, 2 = Peak or Valley Display*			
<b>3</b> 1 = Meter Reset*, 2 = External Gate*			
<b>4</b> 1 = Function Reset*, 2 = Meter Hold*			
<b>5</b> 1 = Valley Only Display, 2 = Peak Only Display			
<b>6</b> 1 = Function Reset*, 2 = External Gate*			
<b>7</b> 1 = Meter Hold*, Peak or Valley Display*			
<b>8</b> 1 = Meter Hold*, 2 = External Gate*			
<b>9</b> 1 = Peak or Valley Display, 2 = External Gate*			
<b>A</b> 1 = Meter Reset*, 2 = Display Blank*			
<b>B</b> 1 = Function Reset*, 2 = Display Blank*			
<b>C</b> 1 = Meter Hold*, 2 = Display Blank*			
<b>D</b> 1 = Peak or Valley Display, 2 = Display Blank*			
<b>E</b> 1 = Display Blank, 2 = External Gate*			
<b>F</b> 1 = Display Item #2*, 2 = Display Item #3*			
-----		With neither 1 nor 2, or both 1 & 2, display Item #1. 1 & 2 both at 0V for selections <b>5</b> , <b>7</b> , <b>D</b> = Function Reset* (erases all totals). 1 & 2 both at 0V for selections <b>0</b> , <b>1</b> , <b>2</b> , <b>3</b> , <b>4</b> , <b>6</b> , <b>8</b> , <b>A</b> , <b>B</b> , <b>C</b> , <b>E</b> = Meter Reset* (can restore totals).	

<b>MENU</b>  <b>Press Menu</b>	<b>PEAK</b>  <b>Press Digit Select Key</b>	<b>RESET</b>  <b>Press Value Select Key</b>
<b>ConFIG</b> Configura- tion	<b>0000</b> Display mode	<b>0</b> Normal, overload to exponential format <b>1</b> Normal, overload to 999999 <b>2</b> 1 right-hand dummy zero <b>3</b> 2 right-hand dummy zeros <b>4</b> Time display in seconds <b>5</b> Time display in HH.MM.SS format <b>6</b> Remote display (H, K, L commands) <b>7</b> Single-value remote display <b>8</b> Show 1 <sup>st</sup> string value, slaved to another meter <b>9</b> Show 2 <sup>nd</sup> string value, slaved to another meter <b>A</b> Show 3 <sup>rd</sup> string value, slaved to another meter <b>B</b> Show 4 <sup>th</sup> string value, slaved to another meter <b>C</b> Custom Start, Stop, Skip, Show
	<b>0000</b> Counter mode	<b>0</b> Basic counter <b>1</b> Extended counter <b>2</b> Extended counter, custom curve #1 selected <b>3</b> Extended counter, custom curve #2 selected
	<b>0000</b> Linearization mode	<b>0</b> Linear rate input. <b>1</b> Square root rate input.
	<b>0000</b> Rate cutoff enable for totalizing	<b>0</b> Do not totalize rate values below <b>CutoffFF</b> value. (avoids totalizing small offsets from 0 rate value or negative rate values). <b>1</b> Totalize all rates (required for bidirectional flow).
<b>dSPyno</b> Display #	<b>01</b> PEAK key action	<b>0</b> Display Peak <b>1</b> Display Valley <b>2</b> Peak (1 <sup>st</sup> push), Valley (2 <sup>nd</sup> push)
	<b>01</b> Item to display after Meter Reset*	<b>1</b> Item #1* <b>2</b> Item #2* <b>3</b> Item #3*
<b>CutoffFF</b> Totalizing cutoff*	<b>00000</b> <b>00000</b> <b>00000</b> <b>00000</b> <b>00000</b> Select digit to flash.	Select <b>0</b> thru <b>9</b> for flashing digits. In A_Atot or Batch modes, meter will not totalize rate values below this cutoff to avoid totalizing small offsets from zero.
<b>GAte t</b> Gate time*	<b>000.00</b> <b>000.00</b> <b>000.00</b> <b>000.00</b> <b>000.00</b> Select digit to flash.	Select <b>0</b> thru <b>9</b> for flashing digit to set gate time* in seconds. Decimal point location is fixed for 10 ms resolution. This is time over which rate is measured.
<b>ti_Out</b> Timeout*	<b>000.00</b> <b>000.00</b> <b>000.00</b> <b>000.00</b> <b>000.00</b> Select digit to flash.	Select <b>0</b> thru <b>9</b> for flashing digit to set timeout* in seconds. Decimal point location is fixed for 10 ms resolution. This is time during which batch relay is de-energized at the end of a batch cycle.

 <b>MENU</b> Press Menu	 <b>PEAK</b> Press Digit Select Key	 <b>RESET</b> Press Value Select Key
<b>bAtCH</b> Batch setup	<b>00000</b> & <b>00000</b>	<b>0</b> Not used with VF Batch. Set to 0.
	<b>00000</b> Batch triggering	<b>0</b> Use gate time* as delay between batches. <b>1</b> Use External Input B to start each new batch.
	<b>00000</b> Definition of Item #2	<b>0</b> Make Item #2 the Grand Total of all batches. <b>1</b> Make Item #2 the Total Number of batches.
	<b>00000</b> Action after Meter Reset	<b>0</b> Display "rEAdy." <b>RESET</b> key starts batching. <b>1</b> Start batching upon Meter Reset.
<b>FiLteR</b> Filtering	<b>00000</b> Signal filtering	<b>0</b> Adaptive moving average filter. Restarts filter for high actual changes in signal. <b>1</b> Conventional moving average filter without reset.
	<b>00000</b> Peak & Valley filtering	<b>0</b> Peak* or Valley* value from unfiltered signal. <b>1</b> Peak* or Valley* value from filtered signal.
	<b>00000</b> Display filtering	<b>0</b> Display value of unfiltered signal. <b>1</b> Display value of filtered signal.
	<b>00000</b> Adaptive filter setup	<b>0</b> Set adaptive filter for normal noise. <b>1</b> Set adaptive filter for presence of high transients.
	<b>00000</b> Filter time constant	<b>0</b> No filter <b>1</b> 0.1 sec <b>2</b> 0.2 sec <b>3</b> 0.4 sec <b>4</b> 0.8 sec <b>5</b> 1.6 sec <b>6</b> 3.2 sec <b>7</b> 6.4 sec
<b>dEC.Pt1</b> Decimal pt1	<b>1.11111</b> Decimal point flashes.	<b>1.11111 11.1111 111.111 1111.11 11111.1 111111.</b> Press <b>▲</b> to shift the decimal point.
<b>dEC.Pt2</b> Decimal pt2	<b>2.22222</b> Decimal point flashes.	<b>2.22222 22.2222 222.222 2222.22 22222.2 222222.</b> Press <b>▲</b> to shift the decimal point.
Scale and Offset scaling method if selected under <b>SEtuP</b>		
<b>SCALE1</b> Scale Factor 1	<b>0.00000 0.00000 0.00000</b> <b>0.00000 0.00000 0.00000</b> Select the digit to flash for the Scale Value, then press <b>▶</b> one more time for the Scale Multiplier.	Select <b>-9</b> thru <b>9</b> for flashing first digit and <b>0</b> thru <b>9</b> for other flashing digits. This will set the Scale Value* from -9.99999 to 9.99999 with a fixed decimal point. Then press <b>▲</b> to select a value from <b>0.00001</b> to <b>100000</b> in decade steps for the Scale Multiplier. Scale Factor = Scale Value x Scale Multiplier.
<b>OFFSt1</b> Offset 1	<b>000000 000000 000000</b> <b>000000 000000 000000</b> Select digit to flash.	Select <b>-9</b> thru <b>9</b> for flashing first digit and <b>0</b> thru <b>9</b> for other flashing digits. Use <b>dEC.Pt1</b> to set the decimal point.
<b>SCALE2</b>	Scale Factor 2.	Make the same Scale Factor 1.
<b>OFFSt2</b>	Offset 2.	Make the same as for Offset 1.

 <b>MENU</b> Press Menu	 <b>PEAK</b> Press Digit Select Key	 <b>RESET</b> Press Value Select Key
Coordinates of 2 points scaling method if selected under <b>SEtuP</b>		
<b>Lo_In1</b> Low signal input 1.	<u>000000</u> <u>000000</u> <u>000000</u> <u>000000</u> <u>000000</u> <u>000000</u> Select digit to flash.	Select <b>9</b> thru <b>9</b> for flashing first digit and <b>0</b> thru <b>9</b> for other flashing digits. Move decimal point location when flashing.
<b>Lo_rd1</b> Reading at Lo In1.	<u>000000</u> <u>000000</u> <u>000000</u> <u>000000</u> <u>000000</u> <u>000000</u> Select digit to flash.	Select <b>9</b> thru <b>9</b> for flashing first digit and <b>0</b> thru <b>9</b> for other flashing digits. Decimal point is fixed by <b>dEC.Pt1</b> .
<b>Hi_In2</b> High signal input 2.	<u>000000</u> <u>000000</u> <u>000000</u> <u>000000</u> <u>000000</u> <u>000000</u> Select digit to flash.	Select <b>9</b> thru <b>9</b> for flashing first digit and <b>0</b> thru <b>9</b> for other flashing digits. Move decimal point location when flashing.
<b>Hi_rd2</b> Reading at Hi In2.	<u>000000</u> <u>000000</u> <u>000000</u> <u>000000</u> <u>000000</u> <u>000000</u> Select digit to flash.	Select <b>9</b> thru <b>9</b> for flashing first digit and <b>0</b> thru <b>9</b> for other flashing digits. Decimal point is fixed by <b>dEC.Pt1</b> .
Special curve offset for square root or custom curve linearization if selected under <b>ConFIG</b>		
<b>rd0_In</b>	<u>000000</u> <u>000000</u> <u>000000</u> <u>000000</u> <u>000000</u> <u>000000</u> Select digit to flash.	Select <b>9</b> thru <b>9</b> for flashing first digit and <b>0</b> thru <b>9</b> for other flashing digits. Decimal point is fixed by <b>dEC.Pt1</b> .
Scale multiplier		
<b>rESoLn</b> Resolution	Flashing 6-digit number in decade steps from <b>0.00001</b> to <b>100000</b>	Press <b>▲</b> to select. This multiplier <b>R</b> appears with the Batch mode and can be applied to Grand Total to set its decimal point.
Quartz crystal time base calibration		
<b>CALib</b>	Time base calibration.	Do not change. See Calibration section of manual.
Option dependent menu items		
<b>Source</b> <b>AL_SEt</b> <b>dEUn1b</b> <b>dEUn2b</b> <b>dEUn1h</b> <b>dEUn2h</b> Menu items related to <b>alarms</b> . These will only appear if relay board is detected. If so, please see Section 13.		
<b>An_SEt</b> <b>An_Lo</b> <b>An_Hi</b> Menu items related to <b>analog output</b> . These will only appear if an analog output board is detected. If so, please see Section 14.		
<b>SEr_1</b> <b>SEr_2</b> <b>SEr_3</b> <b>SEr_4</b> Menu items related to <b>serial communications</b> . These will only appear if an RS232 or RS485 I/O board is detected. If so, please see Section 15.		
Menu lockout items		
<b>Loc_1</b> <b>Loc_2</b> <b>Loc_3</b> <b>Loc_4</b> Menu items used to enable or lock out (hide) other menu items. <b>Loc</b> menu items may be locked out by a hardware jumper. Please see Section 9.		

## 12. QUADRATURE SIGNAL CONDITIONER (QD)

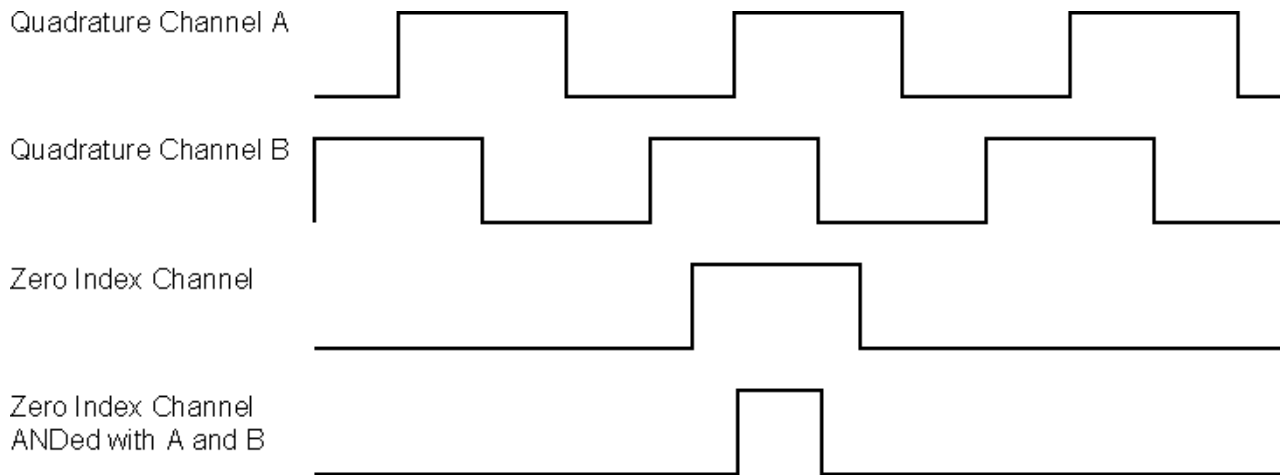

The quadrature signal conditioner board can be used for quadrature position (with Basic or Extended main board) or for quadrature rate (with Extended main board). Two quadrature signals, which are 90° out of phase, are applied to the Channel A and B inputs. Their phase relationship determines whether the count is up (+) or down (-). A zero index signal may be applied to Channel Z as a position reference.

**Position in engineering units** is determined by adding or subtracting transitions, as determined by the signal phase relationship, applying a programmable scale factor to the total, and adding programmable Offset1 to the scaled total. The display update rate is set by a gate time, which is programmed to 10 ms. When the scaled total reaches a programmable Preset, it is reset to Offset 1.

**Rate in engineering units** is determined by measuring Rate A and Rate B in transitions per second for Channels A and B, subtracting Rate B from Rate A, and applying a scale factor. Rate is measured over a gate time, which is programmable from 10 ms to 199.99 sec. Since one of the two channels may not be measuring any pulses over the gate time, a timeout from 10 ms to 199.99 sec is also programmable. The meter update rate will never be less than every timeout. Quadrature rate provides a high resolution, high accuracy display.

**A zero index function** is available to zero the counts in the event of a pulse on a separate zero index channel. This function utilizes the programmable Pulses\* item. This is the number pulses between zero index marks x the edges per pulse (1, 2 or 4) x the scale factor. Since a wide zero index pulse could cause a count discrepancy in the region between transitions, the zero index pulse can be shaped by an AND combination with the A or B channels, as set by jumpers. Please see the diagram at the top of this page, which shows an AND combination of the zero index channel, Channel A and Channel B.

Please see further manual pages for the following features: relay output (49), analog output (51), serial communications (52), parallel BCD output (55), and transducer excitation output (56).

### Jumper Settings

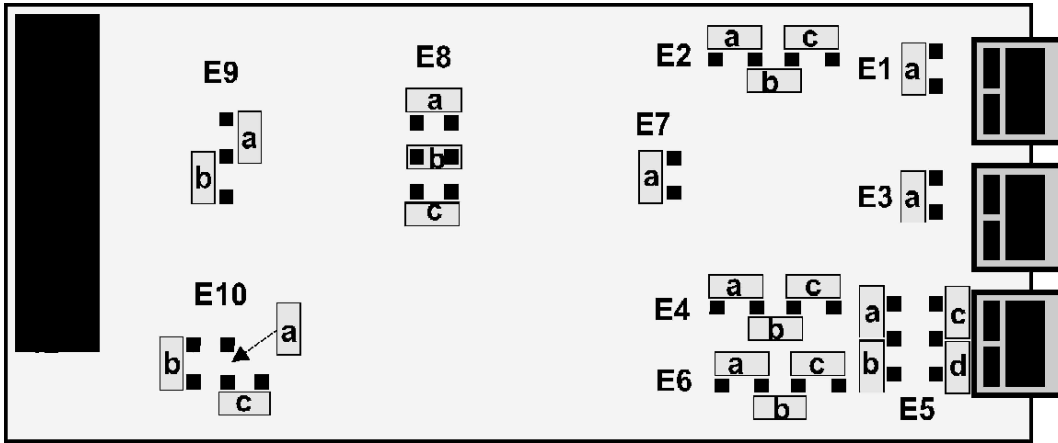

Input Type	E2	E4	E6	E5
Single-ended (signal & return)	a, c	a, c	a, c	c
Differential	b	b	b	c
Differential (with excitation and no zero index)	b	b	-	b, d

Input Termination (for differential inputs only)	E1	E2	E3
For long cable runs	a	a	a
For short cable runs	none	none	none

Phase for Up Count	E7
A positive, negative B transition (A leads B)	none
A positive, positive B transition (B leads A)	a

Count-by Options	E9
X1 = positive edge of A input	none
X2 = positive & negative edges of A input	a
X4 = positive & negative edges of A & B inputs	b

Zero Index Polarity	E7
Positive	a
Negative	none

Zero Index ANDing	E10	E8
Zero Index (no ANDing)	c	-
Zero Index AND /A	a	-
Zero Index AND /B	a	a
Zero Index AND A	a	b
Zero Index AND B	a	a, b
Zero Index AND /A AND /B	b	-
Zero Index AND /A AND B	b	a
Zero Index AND A AND /B	b	b
Zero Index AND A AND B	b	a, b

**PROGRAMMING EXAMPLE FOR QUADRATURE TOTAL:  
DISPLAY DISTANCE TO 0.001 FT FROM A 1024 PULSE/REV QUADRATURE ENCODER**



Dig. No.	S	1	2	3	4	5	6	
InPut			q	u	A	d	r	t o t A L
SEtUP			0	0	1	0	0	
ConFIG				1	0	0	0	
dSPyno						0	1	
PULSES	0	1	0	2	4.			
GAtEt			0	0	0.	1	0	
DecPt1		1	1	1.	1	1	1	
Lo In1		0	0	0	0	0	0	
Lo rd1		0	0	0.	0	0	0	
Hi In1		0	1	0	2	4.	0	
Hi rd1		0	0	1.	7	8	2	
CALib	-		0	0	0	0	0	Do Not Change Calib

**Application:** Display distance in feet with 3 decimal points using a 1024 pulse/revolution quadrature encoder tied to a roller with 1.782 ft circumference.

**Solution:** Set Input to “Quadrature Total.” Set Gate Time to 0.01 sec for fast display updates. Set DecPt1 to 3 places. Under Setup, select coordinates of 2 points scaling method. Set Hi In1 to 1024.0 (pulses) and the desired Hi Rd1 to 1.782 (feet).













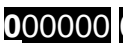
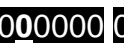



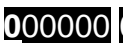
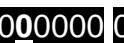





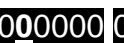

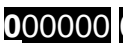
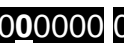

**KEYSTROKES FOR SETUP OF QUADRATURE TOTAL**

If the *MENU*  key does not work, see Section 9 “Enabling & Locking Out Menu Items.”

 <b>MENU</b> Press Menu	 <b>PEAK</b> Press Digit Select Key	 <b>RESET</b> Press Value Select Key
<b>InPut</b> Input	<b>quAdr</b> Quadrature	Basic meter <b>totAL</b> Quadrature total (select for position) Extended <b>rAtE</b> Quadrature rate.
<b>SEtUP</b> Setup	<b>00000</b> Stored totals	<b>0</b> Zero all totals at power-on <b>1</b> Restore totals at power-on. Set <b>PULSES</b> to 0.
	<b>00000</b> Leading zeros	<b>0</b> Blank leading zeros. <b>1</b> Display leading zeros.
	<b>00000</b> Scaling method	<b>0</b> Input scale factor 1 and offset 1 <b>1</b> Use coordinates of 2 points method
	<b>00000</b> Not applicable	<b>0</b> Set to 0.
	<b>00000</b> Operation of rear connector inputs 1 & 2. <b>True</b> = logic 1 (0V or tied to digital ground). <b>False</b> = 0 (5V or open).	<b>0</b> 1 = Meter Reset*, 2 = Function Reset* <b>1</b> 1 = Meter Reset*, 2 = Meter Hold* <b>2</b> 1 = Meter Reset*, 2 = Peak or Valley Display* <b>3</b> 1 = Meter Reset*, 2 = External Gate* <b>4</b> 1 = Function Reset*, 2 = Meter Hold* <b>5</b> 1 = Not applicable to Quadrature Total <b>6</b> 1 = Function Reset*, 2 = External Gate* <b>7</b> 1 = Meter Hold*, 2 = Peak or Valley Display* <b>8</b> 1 = Meter Hold*, 2 = External Gate* <b>9</b> 1 = Peak or Valley Display, 2 = External Gate* <b>A</b> 1 = Meter Reset*, 2 = Display Blank* <b>B</b> 1 = Function Reset*, 2 = Display Blank* <b>C</b> 1 = Meter Hold*, 2 = Display Blank* <b>D</b> 1 = Peak or Valley Display, 2 = Display Blank*



		<b>E</b> 1 = Display Blank, 2 = External Gate* <b>F</b> 1 = Not applicable to Quadrature Total ----- With neither 1 nor 2, or both 1 & 2, display Item #1. 1 & 2 both at 0V for selections <b>5</b> , <b>7</b> , <b>D</b> = Function Reset* (erases all totals). 1 & 2 both at 0V for selections <b>0</b> , <b>1</b> , <b>2</b> , <b>3</b> , <b>4</b> , <b>6</b> , <b>8</b> , <b>A</b> , <b>B</b> , <b>C</b> , <b>E</b> = Meter Reset* (can restore totals).
<b>ConFIG</b> Configura- tion	<b>0000</b> Display mode	<b>0</b> Normal, overload to exponential format <b>1</b> Normal, overload to 999999 Normally select <b>1</b> , required for Preset function. See dual signal conditioner for other available modes.
	<b>0000</b> Counter type	<b>0</b> Basic counter (use for quadrature total) <b>1</b> Extended counter
	<b>0000</b> Square root	<b>0</b> Set to 0.
	<b>0000</b> V-to-F batch	<b>0</b> Set to 0.
<b>dSPyno</b> Display	<b>00</b> Item #	<b>0</b> Set to 0 (ignored for Quadrature Total).
	<b>00</b> Response to PEAK pushbutton	<b>0</b> Peak <b>1</b> Valley <b>2</b> Peak (1 <sup>st</sup> push), Valley (2 <sup>nd</sup> push)
<b>PULSES</b> Zero index pulses*	<b>00000 00000 00000</b> <b>00000 00000</b> Select digit to flash.	Select <b>0</b> thru <b>9</b> for flashing digit to set zero index pulses. This should pulses per revolution x edges per pulse (1, 2 or 4) x scale factor.
<b>GAte t</b> Gate time*	<b>000.00 000.00 000.00</b> <b>000.00 000.00</b> Select digit to flash.	Select <b>0</b> thru <b>9</b> for flashing digit to set the display update rate from 10 ms to 199.99 s.
<b>dEC.Pt1</b> Decimal pt1	<b>1.11111</b> Decimal point flashes.	<b>1.11111 11.1111 111.111 1111.11 11111.1 111111.</b> Press <b>▲</b> to shift decimal point.
Scale and Offset scaling method if selected under <b>SEtuP</b>		
<b>SCALE1</b> Scale Factor 1	<b>0.00000 0.00000 0.00000</b> <b>0.00000 0.00000 0.00000</b> Select the digit to flash for the Scale Value, then press <b>▶</b> one more time for the Scale Multiplier.	Select <b>9</b> thru <b>9</b> for flashing first digit and <b>0</b> thru <b>9</b> for other flashing digits. This will set the Scale Value* from -9.99999 to 9.99999 with a fixed decimal point. Then press <b>▲</b> to select a value from <b>0.00001</b> to <b>100000</b> in decade steps for the Scale Multiplier. Scale Factor = Scale Value x Scale Multiplier.
<b>OFFSt1</b> Offset 1	<b>000000 000000 000000</b> <b>000000 000000 000000</b> Select digit to flash.	Select <b>9</b> thru <b>9</b> for flashing first digit and <b>0</b> thru <b>9</b> for other flashing digits. <b>dEC.Pt1</b> is used for decimal point.

 <b>MENU</b> Press Menu	 <b>PEAK</b> Press Digit Select Key	 <b>RESET</b> Press Value Select Key
Coordinates of 2 points scaling method if selected under <b>SEtUP</b>		
<b>Lo_In1</b> Low signal input 1.	      Select digit to flash.	Select <b>9</b> thru <b>9</b> for flashing first digit and <b>0</b> thru <b>9</b> for other flashing digits. Move decimal point location when flashing.
<b>Lo_rd1</b> Reading at Lo In1.	      Select digit to flash.	Select <b>9</b> thru <b>9</b> for flashing first digit and <b>0</b> thru <b>9</b> for other flashing digits. <b>dEC.Pt1</b> is used for decimal point.
<b>Hi_In1</b> High signal input 2.	      Select digit to flash.	Select <b>9</b> thru <b>9</b> for flashing first digit and <b>0</b> thru <b>9</b> for other flashing digits. Move decimal point location when flashing.
<b>Hi_rd1</b> Reading at Hi In2.	      Select digit to flash.	Select <b>9</b> thru <b>9</b> for flashing first digit and <b>0</b> thru <b>9</b> for other flashing digits. Decimal point is fixed by <b>dEC.Pt1</b> .
<b>PrESet</b> Preset*	      Select digit to flash.	Select <b>9</b> thru <b>9</b> for flashing first digit and <b>0</b> thru <b>9</b> for other flashing digits. <b>dEC.Pt1</b> is used. When the meter counts up and reaches the Preset, it reverts to Offset1. When the meter counts down and reaches Offset1, it reverts to Preset. Set to 0 for no Preset.
<b>CALib</b>	Time base calibration	Not applicable to Total. Do not change value!
Option-dependent menu items		
<b>Source</b> <b>AL_SEt</b> <b>dEUn1b</b> <b>dEUn2b</b> <b>dEUn1h</b> <b>dEUn2h</b> Menu items related to <b>alarms</b> . These will only appear if a relay board is detected. If so, please see Section 13.		
<b>An_SEt</b> <b>An_Lo</b> <b>An_Hi</b> Menu items related to <b>analog output</b> . These will only appear if an analog output board is detected. If so, please see Section 14.		
<b>SEr_1</b> <b>SEr_2</b> <b>SEr_3</b> <b>SEr_4</b> Menu items related to <b>serial communications</b> . These will only appear if an RS232 or RS485 I/O board is detected. If so, please see Section 15.		
Menu lockout items		
<b>Loc_1</b> <b>Loc_2</b> <b>Loc_3</b> <b>Loc_4</b> Menu items used to enable or lock out (hide) other menu items. <b>Loc</b> menu items may be locked out by a hardware jumper. Please see Section 9.		

\* See Glossary for explanation of item.

**PROGRAMMING EXAMPLE FOR QUADRATURE RATE:  
 DISPLAY RATE TO 0.001 FT/SEC FROM A 1024 PULSE/REV QUADRATURE ENCODER**

Dig. No.	S	1	2	3	4	5	6
InPut			q	u	A	d	r
SEtUP			0	0	1	1	0
ConFIG				1	1	0	0
dSPYno						0	1
GAte t			0	0	0.	2	2
ti Out			0	0	1.	0	0
FiLteR			0	0	0	1	0
DecPt1		1	1	1.	1	1	1
DecPt2		2	2	2.	2	2	2
Lo In1		0	0	0	0	0	0
Lo rd1		0	0	0.	0	0	0
Hi In1		0	1	0	2	4.	0
Hi rd1		0	0	1.	7	8	2
Lo In2		0	0	0	0	0	0
Lo rd2		0	0	0.	0	0	0
Hi In2		0	1	0	2	4.	0
Hi rd2		0	0	1.	7	8	2
rESoLn							1
CALib	-		0	0	0	0	0



Do Not Change Calib



**Application:** Display rate in feet/sec with 3 decimal points using a 1024 pulse/revolution quadrature encoder tied to a roller with 1.782 ft circumference. Have 4 display updates per second.

**Solution:** Set Input to “Quadrature Total.” Set Gate Time to .22 sec so that the display update rate becomes .22 sec +30 ms +1 period. Set Time-out to 1 sec, so that pulse rates under 1 Hz are displayed as 0. Set both DecPt1 and DecPt2 to 3 places. Under Setup, select coordinates of 2 points scaling method. Set both Hi In1 and Hi In2 to 1024.0 (pulses/sec) and both the desired Hi Rd1 and Hi Rd2 to 1.782 (feet/sec). Note: the duplicate entries are required because the quadrature meter subtracts counterclockwise pulses from clockwise pulses.

## KEYSTROKES FOR SETUP OF QUADRATURE RATE

If the *MENU*  key does not work, see Section 9 “Enabling & Locking Out Menu Items.”

 <b>MENU</b> Press Menu	 <b>PEAK</b> Press Digit Select Key	 <b>RESET</b> Press Value Select Key
<b>InPut</b> Input	<b>quAdr</b> Quadrature	Basic meter <b>totAL</b> Quadrature total
		Extended <b>rAtE</b> Quadrature rate
<b>SEtuP</b> Setup	<b>00000</b> Not applicable	<b>0</b> Set to zero.
	<b>00000</b> Leading zeros	<b>0</b> Blank leading zeros. <b>1</b> Display leading zeros.
	<b>00000</b> Scaling Method 1	<b>0</b> Input scale factor 1 and offset 1 <b>1</b> Use coordinates of 2 points method
	<b>00000</b> Scaling Method 2	Make the same as Scaling Method 1
	<b>00000</b> Operation of rear connector inputs 1 & 2. <b>True</b> = logic 1 (0V or tied to digital ground). <b>False</b> = 0 (5V or open).	<b>0</b> 1 = Meter Reset*, 2 = Function Reset* <b>1</b> 1 = Meter Reset*, 2 = Meter Hold* <b>2</b> 1 = Meter Reset*, 2 = Peak or Valley Display* <b>3</b> 1 = Meter Reset*, 2 = External Gate* <b>4</b> 1 = Function Reset*, 2 = Meter Hold* <b>5</b> 1 = Valley Only Display, 2 = Peak Only Display <b>6</b> 1 = Function Reset*, 2 = External Gate* <b>7</b> 1 = Meter Hold*, Peak or Valley Display* <b>8</b> 1 = Meter Hold*, 2 = External Gate* <b>9</b> 1 = Peak or Valley Display, 2 = External Gate* <b>A</b> 1 = Meter Reset*, 2 = Display Blank* <b>B</b> 1 = Function Reset*, 2 = Display Blank* <b>C</b> 1 = Meter Hold*, 2 = Display Blank* <b>D</b> 1 = Peak or Valley Display, 2 = Display Blank* <b>E</b> 1 = Display Blank, 2 = External Gate* <b>F</b> 1 = Display Item #2*, 2 = Display Item #3* <hr/> With neither 1 nor 2, or both 1 & 2, display Item #1. 1 & 2 both at 0V for selections <b>5</b> , <b>7</b> , <b>D</b> = Function Reset* (erases all totals). 1 & 2 both at 0V for selections <b>0</b> , <b>1</b> , <b>2</b> , <b>3</b> , <b>4</b> , <b>6</b> , <b>8</b> , <b>A</b> , <b>B</b> , <b>C</b> , <b>E</b> = Meter Reset* (can restore totals).
<b>ConFiG</b> Configura- tion	<b>0000</b> Display mode	<b>0</b> Normal, overload to exponential format <b>1</b> Normal, overload to 999999 Normally select <b>1</b> , required for Preset function. See dual signal conditioner for other available modes.
	<b>0000</b> Counter mode	<b>0</b> Basic counter <b>1</b> Extended counter (required for Quadrature Rate)
	<b>0000</b> Not applicable	<b>0</b> Set to 0.
	<b>0000</b> Not applicable	<b>0</b> Set to 0.

 <b>MENU</b> Press Menu	 <b>PEAK</b> Press Digit Select Key	 <b>RESET</b> Press Value Select Key
<b>dSPyno</b> Display #	<b>01</b> PEAK key action  <b>01</b> Item to display after Meter Reset	<b>0</b> Display Peak <b>1</b> Display Valley <b>2</b> Peak (1 <sup>st</sup> push), Valley (2 <sup>nd</sup> push)  <b>1</b> Item #1* (Quadrature Rate = Rate A - Rate B) <b>2</b> Item #2* (Rate A) <b>3</b> Item #3* (Rate B)
<b>GAtE t</b> Gate time*	<b>000.00 000.00 000.00</b> <b>000.00 000.00</b> Select digit to flash.	Select <b>0</b> thru <b>9</b> for flashing digit to set gate time* in seconds. Decimal point location is fixed for 10 ms resolution.
<b>ti Out</b> Time-out*	<b>000.00 000.00 000.00</b> <b>000.00 000.00</b> Select digit to flash.	Select <b>0</b> thru <b>9</b> for flashing digit to set time-out* in seconds. Decimal point location is fixed for 10 ms resolution.
<b>FiLtEr</b> Filtering	<b>00000</b> Signal filtering	<b>0</b> Adaptive moving average filter. Restarts filter for high actual changes in signal. <b>1</b> Conventional moving average filter without reset.
	<b>00000</b> Peak & Valley filtering	<b>0</b> Peak* or Valley* value from unfiltered signal. <b>1</b> Peak* or Valley* value from filtered signal.
	<b>00000</b> Display filtering	<b>0</b> Display value of unfiltered signal. <b>1</b> Display value of filtered signal.
	<b>00000</b> Adaptive filter setup	<b>0</b> Set adaptive filter for normal noise. <b>1</b> Set adaptive filter for presence of high transients.
	<b>00000</b> Filter time constant	<b>0</b> No filter <b>1</b> 0.1 sec <b>2</b> 0.2 sec <b>3</b> 0.4 sec <b>4</b> 0.8 sec <b>5</b> 1.6 sec <b>6</b> 3.2 sec <b>7</b> 6.4 sec
<b>dEC.Pt1</b> Decimal pt1	<b>1.11111</b> Decimal point flashes.	<b>1.11111 11.1111 111.111 1111.11 11111.1 111111.</b> Press <b>▲</b> to shift decimal point of reading.
<b>dEC.Pt2</b> Decimal pt2	<b>2.22222</b> Decimal point flashes.	Make the same as <b>dEC.Pt1</b>
Scale and Offset scaling method if selected under <b>SEtuP</b>		
<b>SCALE1</b> Scale Factor 1	<b>0.00000 0.00000 0.00000</b> <b>0.00000 0.00000 0.00000</b> Select the digit to flash for the Scale Value, then press <b>▶</b> one more time for the Scale Multiplier.	Select <b>9</b> thru <b>9</b> for flashing first digit and <b>0</b> thru <b>9</b> for other flashing digits. This will set the Scale Value* from -9.99999 to 9.99999 with a fixed decimal point. Then press <b>▲</b> to select a value from <b>0.00001</b> to <b>100000</b> in decade steps for the Scale Multiplier. Scale Factor = Scale Value x Scale Multiplier.
<b>OFFSt1</b> Offset 1	<b>000000 000000 000000</b> <b>000000 000000 000000</b> Select digit to flash.	Select <b>9</b> thru <b>9</b> for flashing first digit and <b>0</b> thru <b>9</b> for other flashing digits. Use <b>dEC.Pt1</b> to set the decimal point.
<b>SCALE2</b>	Scale Factor 2	Make the same as <b>SCALE1</b> .
<b>OFFSt2</b>	Offset 2	Make the same as <b>OFFSt1</b> .

Coordinates of 2 points scaling method if selected under <b>SEtUP</b>		
<b>Lo_In1</b> Low signal input 1.	<u>000000</u> <u>000000</u> <u>000000</u> <u>000000</u> <u>000000</u> <u>000000</u> Select digit to flash.	Select <b>9</b> thru <b>9</b> for flashing first digit and <b>0</b> thru <b>9</b> for other flashing digits. Move decimal point location when flashing.
<b>Lo_rd1</b> Reading at Lo In1.	<u>000000</u> <u>000000</u> <u>000000</u> <u>000000</u> <u>000000</u> <u>000000</u> Select digit to flash.	Select <b>9</b> thru <b>9</b> for flashing first digit and <b>0</b> thru <b>9</b> for other flashing digits. Decimal point is fixed by <b>dEC.Pt1</b> .
<b>Hi_In1</b> High signal input 1.	<u>000000</u> <u>000000</u> <u>000000</u> <u>000000</u> <u>000000</u> <u>000000</u> Select digit to flash.	Select <b>9</b> thru <b>9</b> for flashing first digit and <b>0</b> thru <b>9</b> for other flashing digits. Move decimal point location when flashing.
<b>Hi_rd1</b> Reading at Hi In1.	<u>000000</u> <u>000000</u> <u>000000</u> <u>000000</u> <u>000000</u> <u>000000</u> Select digit to flash.	Select <b>9</b> thru <b>9</b> for flashing first digit and <b>0</b> thru <b>9</b> for other flashing digits. Decimal point is fixed by <b>dEC.Pt1</b> .
<b>Lo_In2</b>	Low signal input 2.	Make the same as <b>Lo_In1</b>
<b>Lo_rd2</b>	Reading at Lo In2	Make the same as <b>Lo_rd1</b>
<b>Hi_In2</b>	High signal input 2	Make the same as <b>Hi_In1</b>
<b>Hi_rd2</b>	Reading at Hi In2.	Make the same as <b>Hi_rd1</b>
Other setup parameters		
<b>rESoLn</b> Reading multiplier	Flashing 6-digit number in decade steps from <u>0.00001</u> to <u>100000</u>	Press <b>▲</b> to select a decade multiplier <b>R</b> for the rate reading. Set to <b>1</b> .
<b>_CALib</b>	Time base calibration	Do not change. See Calibration section of manual.
Option dependent menu items		
<b>Source</b> <b>AL_SEt</b> <b>dEUn1b</b> <b>dEUn2b</b> <b>dEUn1h</b> <b>dEUn2h</b> Menu items related to <b>alarms</b> if a relay board is detected. If so, please see Section13.		
<b>An_SEt</b> <b>An_Lo</b> <b>An_Hi</b> Menu items related to <b>analog output</b> if an analog output board is detected. If so, please see Section14.		
<b>SEr_1</b> <b>SEr_2</b> <b>SEr_3</b> <b>SEr_4</b> Menu items related to <b>serial communications</b> if a serial board is detected. If so, please see Section 15.		
Menu lockout items		
<b>Loc_1</b> <b>Loc_2</b> <b>Loc_3</b> <b>Loc_4</b> Menu items used to enable or lock out (hide) other menu items. <b>Loc</b> menu items may be locked out by a hardware jumper. Please see Section 9.		

## 13. SERIAL INPUT METER / REMOTE DISPLAY OPERATION

With a Basic counter main board and a serial interface board, the counter can operate as a 6-digit serial input meter (or remote display) to display serial data received from a computer or PLC, or act as a slave display to another meter, counter or timer with a serial output. A signal conditioner board is not required, but will not interfere with remote display operation if installed.

The **serial I/O interface** can be provided by any of the following:

- **RS232 board:** single RJ11 connector for point-to-point communications. Shipped with *Custom ASCII Protocol Serial Communications Manual*.
- **RS485 board:** two RJ11 connectors in parallel for multipoint communications, with digital addressing of up to 31 devices. Jumper selectable 2-wire (half duplex) or 4-wire (full duplex) connection. Shipped with *Custom ASCII Protocol Serial Communications Manual*.
- **Modbus RS485 board:** two RJ45 connectors in parallel for multipoint communications, with digital addressing of up to 247 devices. Jumper selectable half duplex (2-wire) or full duplex connection. Shipped with *Modbus Protocol Serial Communications Manual*.

**Slave display operation** to the RS232 output of another meter requires that the jumper **h** be installed on the RS232 board of the slave meter. Also required is a **reversing phone cable**, where the wire colors of the two connectors are reversed from left to right. For more information, please see the Serial Communications Options section of this manual or the Jumper Settings sections of the *Custom ASCII Protocol Serial Communications Manual*.

**With an optional dual relay output board** (contact or solid state relays), the serial input meter can provide remote alarm or control capability. The meter can be programmed so that the relays respond to the displayed reading or to received control characters. For setup information, please see the Dual Relay Output Option section of this manual.

**With the optional analog output board**, the serial input meter can provide an isolated, scalable 4-20 mA, 0-20 mA or 0-10V analog output which tracks the displayed reading, thereby serving as a serial-to-analog converter. For setup information, please see the Analog Output Option section of this manual.

**Front panel setup** required for serial input meter (or remote display) operation is shown on the next page. Two items require special explanation:

- The first digit under **ConFig** item should to be set to a value **6** thru **C**. If no signal conditioner board is detected, the meter defaults to setting **6**, where H, L, K commands are enabled. **H** means display the remote data only. **K** means that the received value is stored as Item #3, to become the source for alarm comparisons and analog output. **L** means both **H** and **K**. In slave mode, the remote meter can display any item of up to four data Items (or string values), such as the Sum of Rates A & B (Item #1), Rate A (Item #2), or Rate B (Item #3).
- A timeout **ti\_Out** can be set to a value from 10 ms to 199.99 sec. This is how long a serial reading will be displayed in the absence of a new serial input. If timeout is set to 0, the display will persist indefinitely in the absence of a new input.



**Additional programmable features** of the serial input meter are detailed in the “Command Mode for Remote Display Operation of Counter / Timer” and “Data Formats” sections of the

*Custom ASCII Protocol Serial Communications Manual.* In particular, Mode 12 (hex C), which is invoked by setting the first digit under *ConFIG* to *C*, allows extraction of data from an ASCII string that contains multiple data values or non-numeric characters. This mode can accommodate selected Start and Stop characters. Any number of characters between the Start character and the data can be masked OFF. Up to 8 display characters (including sign and decimal point) can be masked ON. Any number of characters between the last displayed character and the Stop character can be masked OFF.

*Instrument Setup* software is required to set up parameters for the Remote Display in Mode 12 (hex C). This software is downloadable from our website.

**SELECTED FRONT PANEL SETUP ITEMS FOR SERIAL INPUT METER (not consecutive)**

If the *MENU*  key does not work, see Section 9 “Enabling & Locking Out Menu Items.”



 <b>Press Menu</b>	 <b>Press Digit Select Key</b>	 <b>Press Value Select Key</b>
<b>ConFIG</b> Configuration	<b>0000</b> Display mode	<b>6</b> Remote display (H, K, L commands) <b>7</b> Single-value remote display <b>8</b> Show 1 <sup>st</sup> string value, slaved to another meter <b>9</b> Show 2 <sup>nd</sup> string value, slaved to another meter <b>A</b> Show 3 <sup>rd</sup> string value, slaved to another meter <b>B</b> Show 4 <sup>th</sup> string value, slaved to another meter <b>C</b> Custom Start, Stop, Skip, Show characters
<b>ti_Out</b> Time-out	<b>000.00 000.00 000.00</b> <b>000.00 000.00</b> Select digit to flash.	Select <b>0</b> thru <b>9</b> for flashing digit to set time-out in seconds. Decimal point location is fixed for 10 ms resolution.
<b>SEr 1</b>	<b>000</b> Baud rate Fixed parameters: No parity, 8 data bits, 1 stop bit	<b>0</b> 300 baud <b>1</b> 600 baud <b>2</b> 1200 baud <b>3</b> 2400 baud <b>4</b> 4800 baud <b>5</b> 9600 baud <b>6</b> 19200 baud
<b>SEr 2</b>	<b>0000</b> Meter address	Select <b>0</b> thru <b>F</b> for addresses 1 thru 15. Select <b>0.</b> thru <b>F.</b> (with decimal point) for addresses 16 thru 31.
<b>SEr 3</b>	<b>00000</b> RS485	<b>0</b> Full duplex <b>1</b> Half duplex
<b>SEr 4</b>	<b>000</b> Serial protocol	<b>0</b> Custom ASCII <b>1</b> Modbus RTU <b>2</b> Modbus ASCII
	<b>000</b> Parity	<b>0</b> None <b>1</b> Odd <b>2</b> Even
<b>Addr</b>	<b>000 000 000</b> Modbus address	<b>158</b> Select <b>0</b> through <b>9</b> for flashing digit. Address range is 1 to 247.







## 14. DUAL RELAY OUTPUT OPTION

An optional dual contact relay board or a dual solid state relay board may be installed in the meter main board at plug position P12, adjacent to the power supply board. Once installed, the relay board is recognized by the software, which will bring up the appropriate menu items for it. These menu items will not be brought up if a relay board is not installed. Both relay boards offer a choice of operating modes: latched\* or non-latched\*, hysteresis band\*, deviation band\*, actuation based on the filtered or unfiltered signal, and selectable number of readings in alarm zone to cause an alarm. The source compared to the setpoint may be the displayed item or a non-displayed item. Please see the Glossary at the end of this manual for an explanation of terms marked by an \*.



### VIEWING & CHANGING SETPOINTS



**To view setpoints**, menu item Loc1, digit 4, must have been set to 0. Press the front panel  Alarms key once to light the Alarms 1 indicator and display Setpoint 1. Press the  Alarms key again to light the Alarms 2 indicator and display Setpoint 2. Press the  Alarms key again to return the display to the current reading. The meter continues to make conversions while either setpoint is displayed. If no key is pressed for 30 seconds, the display automatically reverts to the current reading.

**To change setpoints**, menu item Loc4, digit 6, must have been set to 0. Press the  Peak key, and Setpoint 1 will be displayed with a flashing first digit. Press the  Reset key to change the digit value. Press  again to advance to the next digit. Press the  Alarms key to store the changed value. Press the  Peak key again to proceed to Setpoint 2. The meter stops making conversions while either setpoint is being changed. If no key is pressed for 30 seconds, the meter automatically reverts to the normal operation with the old setpoints.

### KEYSTROKES FOR SETUP

If the *MENU*  key does not work, see Section 9 “Enabling & Locking Out Menu Items.”

 <b>MENU</b> Press Menu	 <b>PEAK</b> Press Digit Select Key	 <b>RESET</b> Press Value Select Key
<b>SourceE</b> Source to compare to setpoint	<b>00</b> Setpoint 1 compared to:	<b>1</b> Filtered item <b>1</b> Item #1 <b>2</b> Item #2 <b>3</b> Item #3
	<b>00</b> Setpoint 2 compared to:	<b>0</b> Filtered item <b>1</b> Item #1 <b>2</b> Item #2 <b>3</b> Item #3
<b>AL_Set</b> Alarm Setup	<b>00000</b> Relay state when alarm is active	<b>0</b> Relay 1 on                      Relay 2 on <b>1</b> Relay 1 off                    Relay 2 on <b>2</b> Relay 1 on                    Relay 2 off <b>3</b> Relay 1 off                    Relay 2 off

<b>MENU</b>  Press Menu	<b>PEAK</b>  Press Digit Select Key	<b>RESET</b>  Press Value Select Key
<b>AL_Set</b> (continued)	<b>00000</b> Alarm latching* or non-latching* (auto reset)	<b>0</b> AL1 auto reset AL2 auto reset <b>1</b> AL1 latching AL2 auto reset <b>2</b> AL1 auto reset AL2 latching <b>3</b> AL1 latching AL2 latching
	<b>00000</b> Alarm operates at and above setpoint (active high) or at and below setpoint (active low).	<b>0</b> AL1 active high AL2 active high <b>1</b> AL1 active low AL2 active high <b>2</b> AL1 disabled AL2 active high <b>3</b> AL1 active high AL2 active low <b>4</b> AL1 active low AL2 active low <b>5</b> AL1 disabled AL2 active low <b>6</b> AL1 active high AL2 disabled <b>7</b> AL1 active low AL2 disabled <b>8</b> AL1 disabled AL2 disabled
	<b>00000</b> Hysteresis mode* or band deviation mode*	<b>0</b> AL1 band deviation AL2 band deviation <b>1</b> AL1 hysteresis AL2 band deviation <b>2</b> AL1 band deviation AL2 hysteresis <b>3</b> AL1 hysteresis AL2 hysteresis <b>4</b> No deviation or hysteresis on menu.
	<b>00000</b> Number of consecutive readings in alarm zone to cause an alarm	<b>0</b> After 1 reading <b>1</b> After 2 readings <b>2</b> After 4 readings <b>3</b> After 8 readings <b>4</b> After 16 readings <b>5</b> After 32 readings <b>6</b> After 64 readings <b>7</b> After 128 readings
<b>dEUn1H</b> Alarm 1 hysteresis*	<b>0.00000</b> <b>0.00000</b> <b>0.00000</b> <b>0.00000</b> <b>0.00000</b> <b>0.00000</b> Select digit to flash	Select <b>0</b> thru <b>9</b> for flashing digit. Alarms will operate above and below the setpoint by the value entered.
<b>dEUn2H</b> Alarm 2 hysteresis*	<b>0.00000</b> <b>0.00000</b> <b>0.00000</b> <b>0.00000</b> <b>0.00000</b> <b>0.00000</b> Select digit to flash	Select <b>0</b> thru <b>9</b> for flashing digit. Alarms will operate above and below the setpoint by the value entered.
<b>dEUn1b</b> Alarm 1 band deviation*	<b>0.00000</b> <b>0.00000</b> <b>0.00000</b> <b>0.00000</b> <b>0.00000</b> <b>0.00000</b> Select digit to flash	Select <b>0</b> thru <b>9</b> for flashing digit. Alarms will operate above and below the setpoint by the value entered.
<b>dEUn2b</b> Alarm 2 band deviation*	<b>0.00000</b> <b>0.00000</b> <b>0.00000</b> <b>0.00000</b> <b>0.00000</b> <b>0.00000</b> Select digit to flash	Select <b>0</b> thru <b>9</b> for flashing digit. Alarms will operate above and below the setpoint by the value entered.

\* See Glossary for explanation of item.

## 15. ANALOG OUTPUT OPTION

An optional analog board may be installed in the meter at rear panel jack position J4, adjacent to the signal conditioner board. Once installed, the analog output board is recognized by the meter, which will bring up the appropriate menu items for it. These menu items will not be brought up if an analog output board is not installed.

The analog output board provides 0-20 mA and 0-10 Vdc signals selectable at the connector. These are linearized to the selected meter display. Although both outputs are available, only one is calibrated to specifications. The other output is accurate to  $\pm 1\%$  of the displayed value (typical, 2% max).

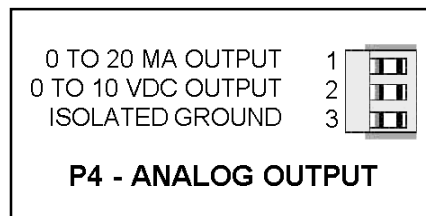





### OUTPUT SCALING

Three analog output spans are selectable: 0-20 mA, 0-10V and 4-20 mA. The low analog output (0 mA, 0V or 4 mA) may be set to correspond to any low displayed reading **An Lo**, and the corresponding high analog output (20 mA, 10V or 20 mA) may be set to correspond to any high displayed reading **An Hi**. The meter will then apply a straight line fit between these two end points to provide an analog output that is scaled to the displayed reading.

### KEYSTROKES FOR SETUP

If the *MENU*  key does not work, see Section 9 “Enabling & Locking Out Menu Items.”

 <b>Press Menu Key</b>	 <b>Press Digit Select Key</b>	 <b>Press Value Select Key</b>
<b>An_SEt</b> Analog Output Setup. Press  until <i>AnSEt</i> is displayed (requires analog output board).	<div style="border: 1px solid black; padding: 2px; margin-bottom: 5px; text-align: center;">00</div> Calibration output selection.	<div style="border: 1px solid black; padding: 2px; margin-bottom: 5px; text-align: center;">0</div> 0-20 mA current output <div style="border: 1px solid black; padding: 2px; margin-bottom: 5px; text-align: center;">1</div> 0-10V voltage output <div style="border: 1px solid black; padding: 2px; margin-bottom: 5px; text-align: center;">2</div> 4-20 mA current output
	<div style="border: 1px solid black; padding: 2px; margin-bottom: 5px; text-align: center;">00</div> Analog output source.	<div style="border: 1px solid black; padding: 2px; margin-bottom: 5px; text-align: center;">0</div> Filtered item <div style="border: 1px solid black; padding: 2px; margin-bottom: 5px; text-align: center;">1</div> Item 1 <div style="border: 1px solid black; padding: 2px; margin-bottom: 5px; text-align: center;">2</div> Item 2 <div style="border: 1px solid black; padding: 2px; margin-bottom: 5px; text-align: center;">3</div> Item 3
<b>An_Lo</b> Low displayed value for 0V, 0 mA, or 4 mA output	<div style="border: 1px solid black; padding: 2px; margin-bottom: 5px; text-align: center;">0.00000 0.00000 0.00000</div> <div style="border: 1px solid black; padding: 2px; margin-bottom: 5px; text-align: center;">0.00000 0.00000 0.00000</div> Select digit to flash	Select <b>0</b> thru <b>9</b> for flashing digit. Decimal point location is fixed by <b>dEC.Pt1</b> selection.
<b>An_Hi</b> High displayed value for 10V or 20 mA output	<div style="border: 1px solid black; padding: 2px; margin-bottom: 5px; text-align: center;">0.00000 0.00000 0.00000</div> <div style="border: 1px solid black; padding: 2px; margin-bottom: 5px; text-align: center;">0.00000 0.00000 0.00000</div> Select digit to flash	Select <b>0</b> thru <b>9</b> for flashing digit. Decimal point location is fixed by <b>dEC.Pt1</b> selection.

## 16. SERIAL COMMUNICATIONS OPTIONS

An optional serial communications board (RS232, RS485 or Modbus-RS485) may be connected to the meter main board at plug position P13 (middle position). Once installed, this board is recognized by the meter, which will bring up the appropriate serial communication menu items. These items will not be brought up if a communication board is not installed.

The RS485 and RS485-Modbus boards are electrically equivalent, but have a slightly different physical layout. The RS485 version uses two RJ11 connectors, while the Modbus-RS485 version uses two RJ45 connectors for compliance with the Modbus standard. The dual connectors of both boards are wired in parallel to allow daisy chaining with no need for a communications hub.

All three boards are compatible with the same serial three communication protocols, which are selectable under meter setup: Custom ASCII, Modbus RTU, and Modbus ASCII. For voltage reasons, use of multiple meters on the same serial line requires an RS485 or Modbus-RS485 board.

For serial programming details, please see the *Custom ASCII Protocol Serial Communications Manual*, which is shipped with RS232 or RS485 boards, or the *Modbus Protocol Serial Communications Manual*, which is shipped with the Modbus-RS485 board.

### BOARD SETUP VIA JUMPERS

#### RS232 Board

- g** - Normal operation.
- h** - Slave display operation to RS232 output of another meter.
- J** - Pull-up resistor on RTS line.

**Note:** The board is shipped standard with jumpers **g** and **j** installed.



#### RS485 and RS485-Modbus Boards

##### *Full Duplex Operation*

- b & e** - These bias jumpers should be installed on 1 (and only 1) meter.
- a & d** - Installed on last meter in line with long cable runs.

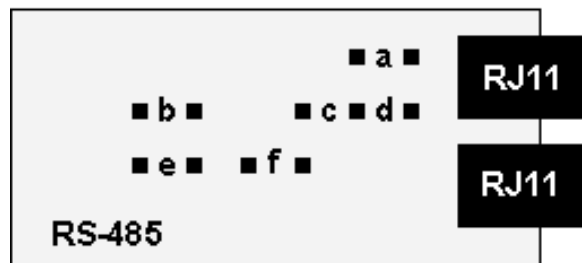

##### *Half Duplex Operation*



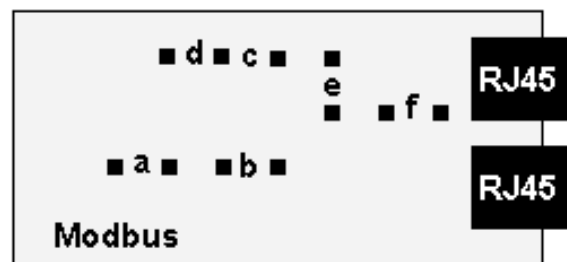

- b & e** - Bias jumpers installed on 1 board.
- c & f** - Installed for half duplex operation.
- a** - Installed on last meter in line with long cable runs.



**Note:** The boards are shipped with no jumpers installed.



## KEYSTROKES FOR SETUP

If the *MENU*  key does not work, see Section 9 “Enabling & Locking Out Menu Items.”

 <b>Press Menu Key</b>	 <b>Press Digit Select Key</b>	 <b>Press Value Select Key</b>																																
<b>Ser 1</b> Serial Setup 1. Press  until <i>Ser 1</i> is displayed.  <u>Fixed Parameters</u> No parity 8 data bits 1 stop bit	<b>000</b> Output filtering	<b>0</b> Send unfiltered signal <b>1</b> Send filtered signal																																
	<b>000</b> Baud rate	<b>0</b> 300 baud <b>1</b> 600 baud <b>2</b> 1200 baud <b>3</b> 2400 baud <b>4</b> 4800 baud <b>5</b> 9600 baud <b>6</b> 19200 baud																																
	<b>000</b> Output update rate	<table style="width: 100%; border: none;"> <tr> <td style="width: 50%;"></td> <td style="text-align: center;"><u>60 Hz</u></td> <td style="text-align: center;"><u>50 Hz</u></td> </tr> <tr> <td><b>0</b></td> <td>Line frequency</td> <td></td> </tr> <tr> <td><b>1</b></td> <td>0.28 sec</td> <td>0.34 sec</td> </tr> <tr> <td><b>2</b></td> <td>0.57 sec</td> <td>0.68 sec</td> </tr> <tr> <td><b>3</b></td> <td>1.1 sec</td> <td>1.4 sec</td> </tr> <tr> <td><b>4</b></td> <td>2.3 sec</td> <td>2.7 sec</td> </tr> <tr> <td><b>5</b></td> <td>4.5 sec</td> <td>5.4 sec</td> </tr> <tr> <td><b>6</b></td> <td>9.1 sec</td> <td>10.9 sec</td> </tr> <tr> <td><b>7</b></td> <td>18.1 sec</td> <td>21.8 sec</td> </tr> <tr> <td><b>8</b></td> <td>36.6 sec</td> <td>43.5 sec</td> </tr> <tr> <td><b>9</b></td> <td>72.5 sec</td> <td>97 sec</td> </tr> </table>		<u>60 Hz</u>	<u>50 Hz</u>	<b>0</b>	Line frequency		<b>1</b>	0.28 sec	0.34 sec	<b>2</b>	0.57 sec	0.68 sec	<b>3</b>	1.1 sec	1.4 sec	<b>4</b>	2.3 sec	2.7 sec	<b>5</b>	4.5 sec	5.4 sec	<b>6</b>	9.1 sec	10.9 sec	<b>7</b>	18.1 sec	21.8 sec	<b>8</b>	36.6 sec	43.5 sec	<b>9</b>	72.5 sec
	<u>60 Hz</u>	<u>50 Hz</u>																																
<b>0</b>	Line frequency																																	
<b>1</b>	0.28 sec	0.34 sec																																
<b>2</b>	0.57 sec	0.68 sec																																
<b>3</b>	1.1 sec	1.4 sec																																
<b>4</b>	2.3 sec	2.7 sec																																
<b>5</b>	4.5 sec	5.4 sec																																
<b>6</b>	9.1 sec	10.9 sec																																
<b>7</b>	18.1 sec	21.8 sec																																
<b>8</b>	36.6 sec	43.5 sec																																
<b>9</b>	72.5 sec	97 sec																																
<b>Ser 2</b> Serial Setup 2	<b>0000</b> Line feed	<b>0</b> No LF after carriage return <b>1</b> LF after carriage return																																
	<b>0000</b> Alarm data with readings	<b>0</b> No alarm data <b>1</b> Alarm data with reading																																
	<b>0000</b> Output mode control	<b>0</b> Continuous data output <b>1</b> Data output on ASCII command only																																
	<b>0000</b> Meter address with Custom ASCII protocol*	Select <b>0</b> thru <b>F</b> for addresses 1 thru 15. Select <b>0.</b> thru <b>F.</b> (with decimal point) for addresses 16 thru 31.																																
<b>Ser 3</b> Serial Setup 3	<b>00000</b> Half or full duplex	<b>0</b> Full duplex <b>1</b> Half duplex																																
	<b>00000</b> Special transmission characters.	<b>0</b> None <b>1</b> Special start & stop characters																																
	<b>00000</b> RTS mode	<b>0</b> Normal RTS <b>1</b> Single transmission																																

<b>MENU</b>  <b>Press Menu Key</b>	<b>PEAK</b>  <b>Press Digit Select Key</b>	<b>RESET</b>  <b>Press Value Select Key</b>
<b>Ser 3</b> (continued)	<b>00000</b> CR (LF) termination characters.	<b>0</b> Only at end of all items <b>1</b> At end of each item
	<b>00000</b> Data sent in continuous mode	<b>0</b> All Active Items <b>1</b> Item #1 only <b>2</b> Item #2 only (if active) <b>3</b> Item #3 only (if active) <b>4</b> Peak only <b>5</b> Displayed Item <b>6</b> Valley only <b>7</b> All Active Items + Peak + Valley
<b>Ser 4</b> Serial Setup 4	<b>000</b> Modbus* ASCII gap timeout	<b>0</b> 1 sec <b>1</b> 3 sec <b>2</b> 5 sec <b>3</b> 10 sec
	<b>000</b> Serial protocol	<b>0</b> Custom ASCII* <b>1</b> Modbus* RTU <b>2</b> Modbus* ASCII
	<b>000</b> Parity	<b>0</b> None <b>1</b> Odd <b>2</b> Even
<b>Addr</b> Modbus Address	<b>000</b> <b>000</b> <b>000</b> Select digit to flash.	<b>158</b> Select <b>0</b> thru <b>9</b> for flashing digit. Address range is 1 to 247.

\* See Glossary for explanation of item.

## 17. PARALLEL BCD OUTPUT OPTION

An optional parallel BCD output board may be installed in the meter at rear panel jack position J3 (middle position). Once installed, the board is recognized by the meter, which will bring up the appropriate menu items. These menu items will not be brought up if a BCD board is not installed.

### BCD OUTPUT LEVELS

The BCD board provides isolated, buffered, stored, 3-state parallel outputs that are selectable for either 0 to 5V logic levels (LSTTL, CMOS compatible) or 0 to 15 Vdc. Level selection is via jumpers on the BCD board. BCD outputs are positive true. Polarity bit is positive true for +sign.

Logic Level	Jumper
0 to 5 Vdc	b
0 to 15 Vdc	a

### BCD CONTROL SIGNALS

- Enable      Logic 0 - All outputs go to the high impedance state  
                  Logic 1 - BCD information is available at outputs.
- BCD Hold    Logic 0 - BCD from last update prior to BCD Hold going low is stored  
                  Logic 1 - BCD information updates at selected rate.
- Data Ready   Logic 0 - BCD outputs are valid  
                  Logic 1 - BCD outputs are not valid

### KEYSTROKES FOR SETUP

If the *MENU* key does not work, see Section 9 “Enabling & Locking Out Menu Items.”

<b>Press Menu Key</b>	<b>Press Digit Select Key</b>	<b>Press Value Select Key</b>																																	
<b>Ser 1</b> Press  until <i>Ser 1</i> is displayed.	<u>0</u> <u>0</u> Output filtering	<u>0</u> Send unfiltered signal <u>1</u> Send filtered signal																																	
	<u>0</u> <u>0</u> Output update rate	<table style="width: 100%; border: none;"> <tr> <td style="width: 50%;"></td> <td style="text-align: center;"><u>60 Hz</u></td> <td style="text-align: center;"><u>50 Hz</u></td> </tr> <tr> <td style="border: none;"><b>0</b></td> <td style="border: none;">Line frequency</td> <td style="border: none;"></td> </tr> <tr> <td style="border: none;"><b>1</b></td> <td style="border: none;">0.28 sec</td> <td style="border: none;">0.34 sec</td> </tr> <tr> <td style="border: none;"><b>2</b></td> <td style="border: none;">0.57 sec</td> <td style="border: none;">0.68 sec</td> </tr> <tr> <td style="border: none;"><b>3</b></td> <td style="border: none;">1.1 sec</td> <td style="border: none;">1.4 sec</td> </tr> <tr> <td style="border: none;"><b>4</b></td> <td style="border: none;">2.3 sec</td> <td style="border: none;">2.7 sec</td> </tr> <tr> <td style="border: none;"><b>5</b></td> <td style="border: none;">4.5 sec</td> <td style="border: none;">5.4 sec</td> </tr> <tr> <td style="border: none;"><b>6</b></td> <td style="border: none;">9.1 sec</td> <td style="border: none;">10.9 sec</td> </tr> <tr> <td style="border: none;"><b>7</b></td> <td style="border: none;">18.1 sec</td> <td style="border: none;">21.8 sec</td> </tr> <tr> <td style="border: none;"><b>8</b></td> <td style="border: none;">36.6 sec</td> <td style="border: none;">43.5 sec</td> </tr> <tr> <td style="border: none;"><b>9</b></td> <td style="border: none;">72.5 sec</td> <td style="border: none;">97 sec</td> </tr> </table>		<u>60 Hz</u>	<u>50 Hz</u>	<b>0</b>	Line frequency		<b>1</b>	0.28 sec	0.34 sec	<b>2</b>	0.57 sec	0.68 sec	<b>3</b>	1.1 sec	1.4 sec	<b>4</b>	2.3 sec	2.7 sec	<b>5</b>	4.5 sec	5.4 sec	<b>6</b>	9.1 sec	10.9 sec	<b>7</b>	18.1 sec	21.8 sec	<b>8</b>	36.6 sec	43.5 sec	<b>9</b>	72.5 sec	97 sec
	<u>60 Hz</u>	<u>50 Hz</u>																																	
<b>0</b>	Line frequency																																		
<b>1</b>	0.28 sec	0.34 sec																																	
<b>2</b>	0.57 sec	0.68 sec																																	
<b>3</b>	1.1 sec	1.4 sec																																	
<b>4</b>	2.3 sec	2.7 sec																																	
<b>5</b>	4.5 sec	5.4 sec																																	
<b>6</b>	9.1 sec	10.9 sec																																	
<b>7</b>	18.1 sec	21.8 sec																																	
<b>8</b>	36.6 sec	43.5 sec																																	
<b>9</b>	72.5 sec	97 sec																																	

## 18. EXCITATION OUTPUTS & POWER SUPPLY

Three isolated transducer excitation output levels are available from the power supply board. These are selectable via jumpers b, c, d, e, f in the upper right of the board, as illustrated. In addition, the board provides three jumper positions for special features. The same jumper locations apply to the universal power supply (95-240 Vac  $\pm$ 10% or 95-300 Vdc) and to the low voltage power supply (10-34 Vac or 10-48 Vdc).

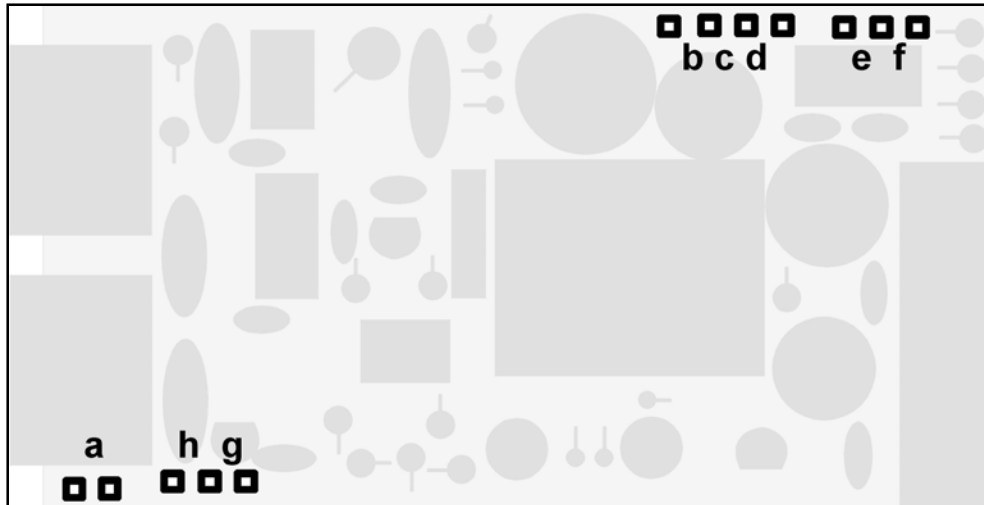

Excitation output	Jumper locations											
5 Vdc $\pm$ 5%, 100 mA max	<b>b, d, e</b>	<table style="margin: auto; border: none;"> <tr> <td style="text-align: center;">b</td> <td style="text-align: center;">d</td> <td style="text-align: center;">e</td> </tr> <tr> <td style="text-align: center;">■</td><td style="text-align: center;">■</td> <td style="text-align: center;">■</td><td style="text-align: center;">■</td> <td style="text-align: center;">■</td><td style="text-align: center;">■</td><td style="text-align: center;">■</td> </tr> </table>	b	d	e	■	■	■	■	■	■	■
b	d	e										
■	■	■	■	■	■	■						
10 Vdc $\pm$ 5%, 120 mA max	<b>b, d, f</b>	<table style="margin: auto; border: none;"> <tr> <td style="text-align: center;">b</td> <td style="text-align: center;">d</td> <td style="text-align: center;">f</td> </tr> <tr> <td style="text-align: center;">■</td><td style="text-align: center;">■</td> <td style="text-align: center;">■</td><td style="text-align: center;">■</td> <td style="text-align: center;">■</td><td style="text-align: center;">■</td><td style="text-align: center;">■</td> </tr> </table>	b	d	f	■	■	■	■	■	■	■
b	d	f										
■	■	■	■	■	■	■						
24 Vdc $\pm$ 5%, 50 mA max	<b>c</b>	<table style="margin: auto; border: none;"> <tr> <td style="text-align: center;">c</td> </tr> <tr> <td style="text-align: center;">■</td><td style="text-align: center;">■</td><td style="text-align: center;">■</td><td style="text-align: center;">■</td> </tr> </table>	c	■	■	■	■					
c												
■	■	■	■									

### 22.2 SELECTION OF OTHER JUMPERS

- Jumper a** - Front panel menu lockout, locked when installed. (See Section 9)
- Jumper g** - Provides +5V power output at P1-4 when installed.
- Jumper h** - Connects "Digital Input B" to P1-4 when installed.



## 19. INSTRUMENT SETUP VIA PC

*Instrument Setup* software is a PC program which is much easier to learn than front panel programming. It is of benefit whether or not the meter is connected to a PC. With the meter connected to a PC, it allows uploading, editing and downloading of setup data, execution of commands under computer control, listing, plotting and graphing of data, and computer prompted calibration. With the meter unconnected to a PC, it provides quick selection of jumper locations and a printable display of menu selections for front panel setup.

### SOFTWARE INSTALLATION

Download *IS2\*.exe* onto your PC from the web or the distribution CD. Double-click on the downloaded file to unzip it into a special directory, such as *c:\temp*. Within that directory, double-click on *setup.exe*, which will install the software on your PC.

### PREREQUISITES FOR CONNECTED USE

- 1) PC with available RS232 com port.
- 2) Meter to be set up.
- 3) RS232 board in meter. This board can be used for setup, then be removed.
- 4) RJ11-to-DB9 RS232 cable to connect meter and PC (see Section 1, Ordering Guide).
- 5) *Instrument Setup* software.

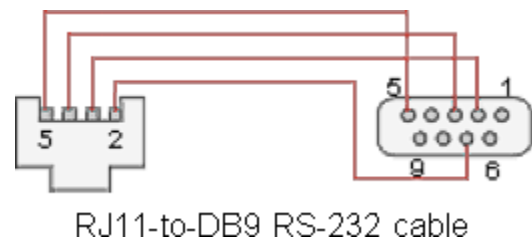

### ESTABLISHING COMMUNICATIONS

Connect the meter and PC. Apply power to the meter. Be sure that the meter is in Run Mode, not Setup Mode. To start the software from Windows, click on *Start => Programs => IS2 => IS2*. Click on *RS232 => Establish*. The program will temporarily set the selected Com port to the required baud rate, parity, data bits and stop bit. Once communications have been established, click on *Main Menu*. The software will sense the type of meter and installed boards, but it cannot sense jumpers positions nor set jumpers for you. If the computer is not connected to a meter, select *Counter/Timer* and *Series 2*.

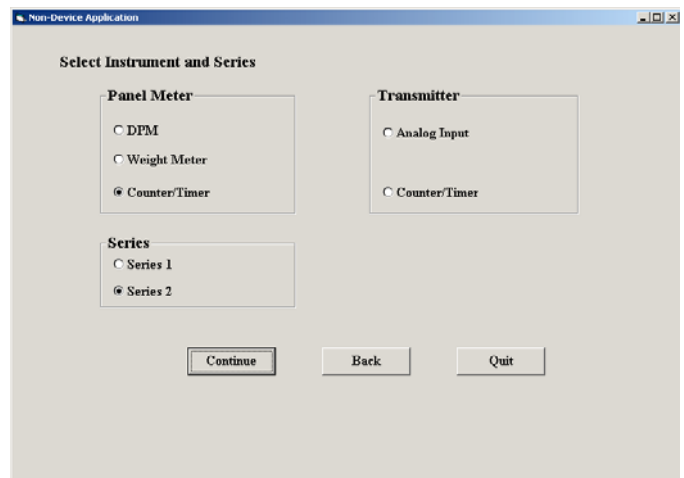
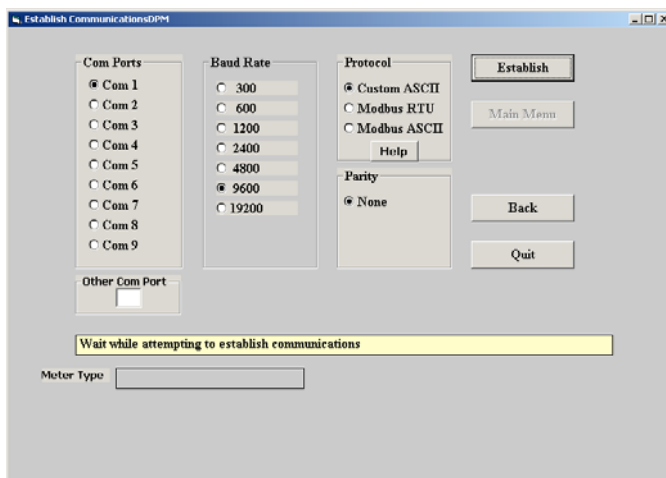

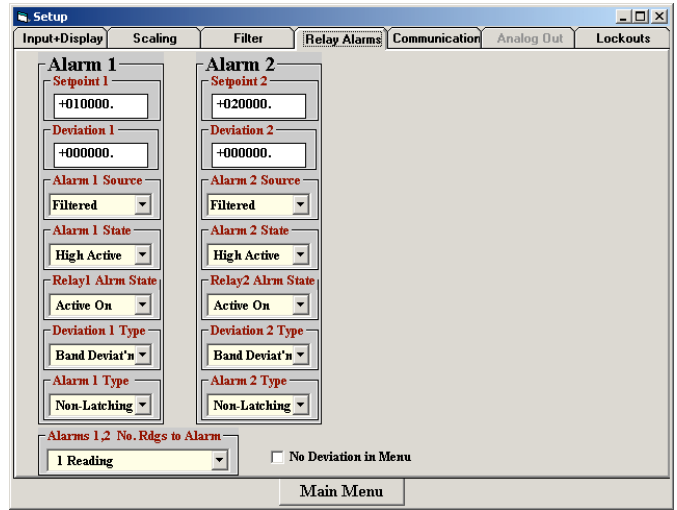
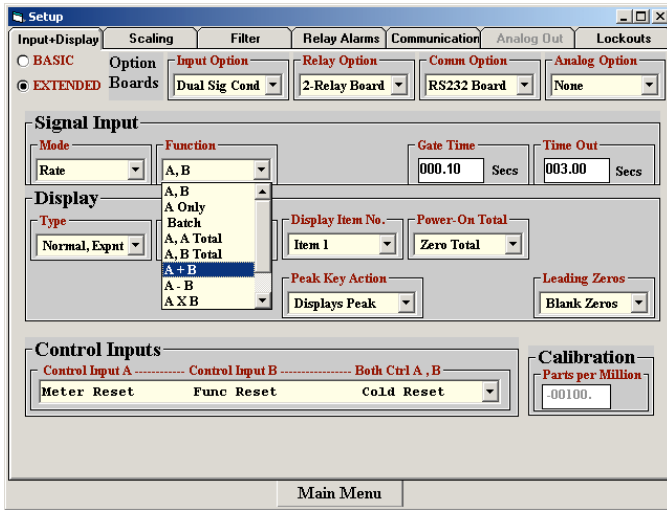

## SETUP OF CONNECTED METER

A setup file can be retrieved from the meter (*Counter => Get Setup*), be edited (*View => Setup*), be saved to disk (*File => Save Setup*), be retrieved from disk (*File => Open Setup*), and be downloaded into one or multiple meters (*Counter => Put Setup*). Downloading of setup files from a PC can be a major time saving when multiple counters have to be set up in the same way.

You will find that *Instrument Setup* software is very user friendly, with separate tab-selectable windows for *Input+Display*, *Scaling*, *Filter*, *Relay Alarms*, *Communications*, *Analog Out*, and *Lockouts*. If the required hardware, such as the analog output board, is not sensed, the corresponding tab will be grayed out.

## ADDITIONAL FEATURES WHEN CONNECTED

- **The Commands pull-down menu** allows you to perform Reset functions, to enter numerical values into the meter, and to retrieve numerical values from the meter (Items 1, 2, 3, Peak, Valley).

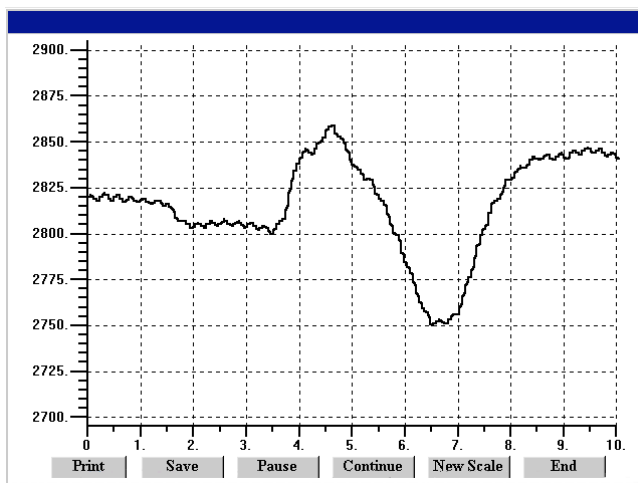

Plot

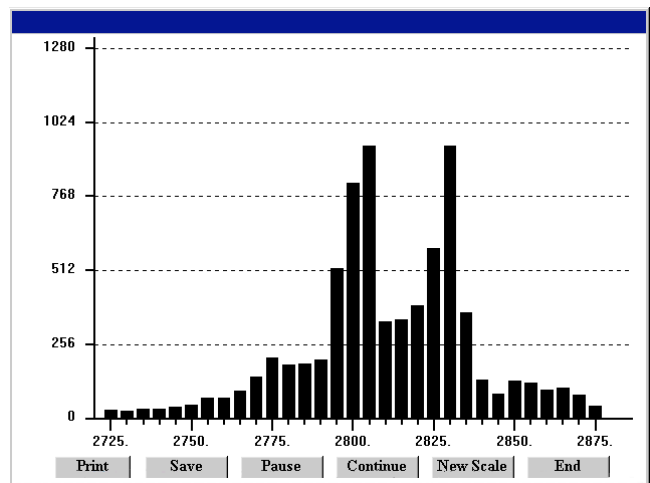

Graph

- **The Readings pull-down menu** provides three formats to display meter data on the PC monitor. Use the *Pause* and *Continue* buttons to control the timing of data collection, then press *Print* for a hardcopy record on your PC printer.
  - **List** presents the latest readings in a 20-row by 10-column table. Press *Pause* at any time to freeze the display. This is one method to capture peak readings.
  - **Plot** generates a plot of readings vs. time in seconds. It effectively turns the DPM-PC combination into a printing digital oscilloscope.
  - **Graph** generates a histogram, where the horizontal axis is the reading and the vertical axis is the number of occurrences of readings. The display continually resizes itself as the number of readings increases.
- **The Jumpers pull-down menu** shows board jumper corresponding to specific user selections.
- **The Calibration pull-down menu** allows easy frequency calibration of the quartz crystal. Simply apply a known calibration frequency up to 1 MHz to Channel A of the dual channel signal conditioner board, type in the frequency value in Hz, and press *Enter*.

### METER SETUP WITH AN UNCONNECTED PC

*Instrument Setup* software is also of benefit when the PC is not connected to a meter.

Upon launching the software, click on *None* for *Communications*, then on *Counter/Timer* and *Series 2*. Click on *File => Default Setup* to retrieve a default setup file from disk, or on *File => Open Setup* to retrieve a previously saved setup file from disk.

To enter new setup information, click on *View => Setup*, then make your screen selections as if you were connected to a meter. Tabs will be grayed out if you have not selected the required hardware under the *Input+Display* tab. When done, press on *Main Menu*, then on *View => Menu*. The selections made under *Setup* will now be shown in the form of the required front panel programming sequence, where each row corresponds to a menu item selected by the **→** key, and the seven data columns correspond to values entered via the **▶** and **▲** keys.

Click on any step in the sequence to bring up a detailed help window.

Click on *Print* for a hardcopy, which you can then use as an instruction sheet to program your meter via its front panel.

Click on *Main Menu => File => Save Setup As* to save your setup to disk and have an electronic record.

Dig. No.	S	1	2	3	4	5	6
InPut				r	A	t	E
SEtUP		0	0	0	0	0	0
ConFiG				0	1	0	0
dSPyno						0	1
GAte t			0	0	0.	1	0
ti Out			0	0	3.	0	0
FILtEr			0	0	0	1	1
SLOPE						0	1
DecPt1		1	1	1	1	1	1.
DecPt2		2	2	2	2	2	2.
SCALE1	+	1.	0	0	0	0	0
OFFSt1	+	0	0	0	0	0	0
SCALE2	+	1.	0	0	0	0	0
OFFSt2	+	0	0	0	0	0	0
SourcE				1	1		
AL SEt			0	0	0	0	0
dEUn1b	+	0	0	0	0	0	0
dEUn2b	+	0	0	0	0	0	0
SEr 1					0	5	0
SEr 2				0	0	1	1
SEr 3			0	0	0	0	1
SEr 4					0	1	0
Addr					0	0	1
CALib	-		0	0	1	0	0
Loc 1				0	0	0	0
Loc 2				0	0	0	0
Loc 3				0	0	0	0
Loc 4				0	0	0	0

## 20. CUSTOM CURVE LINEARIZATION

*Curve.exe* is a DOS-based, executable PC program used to set up an Extended meter\* so that the readings have a user-defined, non-linear relationship with the input signal. The calculated linearizing parameters are downloaded into non-volatile memory of the meter. For example, it allows a meter to correct for non-linearity of nominally linear transducers, or to display volume from liquid level or from pressure at the bottom of an irregularly shaped tank. The curve fitting algorithm uses quadratic segments of varying length and curvature, and provides diagnostics to estimate curve fitting errors. The program is self-prompting, avoiding the need for a detailed printed manual. This manual section is only intended as an introduction and get-started guide.

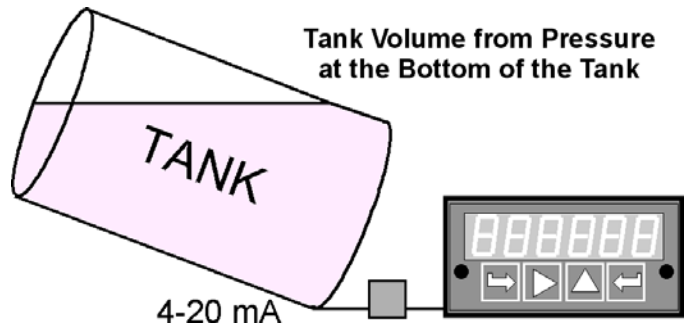

### PREREQUISITES

- 1) PC-compatible computer with an available Com 1 or Com 2 RS232 port.
- 2) Extended meter\*.
- 3) An RS232 board in the meter. This board can be used for meter setup only, then be removed.
- 4) An RJ11-to-DB9 RS232 cable to connect the meter and PC (see Section 1, Ordering Guide).
- 5) *Curve.exe* software (downloadable from the web at no charge).

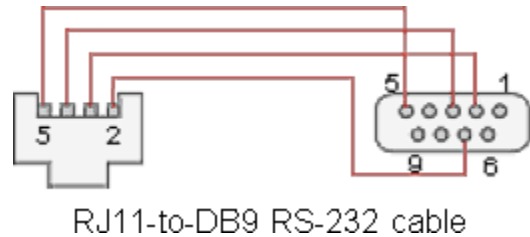

### GETTING STARTED

Download *curve.exe* into the same directory that will contain your data files, such as *c:\curves*. Set the meter to custom curve linearization. To do so, press the **→** key to get to **ConFG**, then set the fifth digit to **1**. This digit will only be displayed with an Extended meter\*. Set the meter baud rate to 9600. To do so, press the **→** key to get to **SEr 1**, then set the entry to **050**. Set the meter address to 1. To do so, press the **→** key to get to **SEr 2**, then set the entry to **0011**. To execute the program from Windows, simply double-click on *curve.exe*. No software installation is required.

### OPERATING MODES

The program will prompt you to enter your data in one of four modes. Pressing **R** (Enter) at any time returns you to the main menu.

- 1) **Text file entry mode**, with an X value in one column and a Y value in another. There can be additional columns, which are ignored. The file must have a DOS name of up to 8 characters and the extension **.RAW**. There can be from 5 to 180 rows. X is the input value and should be in the unit of measure for which the meter was set up, such as mV, V, mA or A. Y is the desired corresponding reading and can range from -99999 to 99999 with any decimal point.

- 2) **2-coordinate keyboard entry mode**, where an actual X input signal is applied, and the desired Y reading is entered from the keyboard.
- 3) **2-coordinate file entry mode**, where an actual X input signal is applied, and the desired Y reading is provided from a file.
- 4) **Equation entry mode**, where the coefficients of a polynomial  $Y = K1X^P1 + K2X^P2 + K3X^P3 + \dots$  are entered. Up to 20 terms are allowed. And offset can be built into X.

## REQUIRED USER INPUTS

- You will be asked if your DPM has a revision of DPM4L or later. You will normally select **2** (yes), since revision DPM4L started to ship in August 2000.
- You will be asked to supply the following:  
 LOW X-COORDINATE VALUE >  
 LOW INPUT MEASUREMENT VALUE >  
 HIGH X-COORDINATE VALUE >  
 HIGH INPUT MEASUREMENT VALUE >  
 This informs the computer of your signal conditioner jumper settings. Enter 0 and 0 for the two LOW values. For HIGH X, enter your signal conditioner jumper range in the same units of measure that you will be using in your \*.RAW data input file. Enter **20** for 20 mV or 20V. Enter **200** for 200 mV or 200V. Enter **5** for 5A AC or DC. For HIGH INPUT MEASUREMENT VALUE, enter **20000**, except for 5A DC, where you should enter **5000**.
- You will be asked to select the position of the decimal point from 6=X.XXXXX, 5=XX.XXX, 4=XXX.XXX, 3=XXXX.XX, 2=XXXXX.X, 1=XXXXXX (for DPMs, the leading X is a blank). Specify the same position that you specified in the **dEc.Pt1** decimal point menu selection.

## FILES USED OR CREATED BY CURVE.EXE

- 1) **\*.RAW** is the raw input file generated by all four data entry methods.
- 2) **\*.DVD** adds three columns from which the smoothness of the input data and obvious input errors can be judged. The more data points and the smoother the data, the better the curve fit.
- 3) **\*.NUM** lists Y readings prior to custom curve linearization and addition of the decimal point.
- 4) **\*.CCF** is an internal file used by the software.
- 5) **\*.SIM** lists simulated linearized meter readings and calculated corresponding errors.
- 6) **\*.PRM** contains the final hex data that is downloaded into the meter.

## 21. METER CALIBRATION

All ranges of the meter have been digitally calibrated at the factory prior to shipment using computers and calibration equipment certified to NIST standards. If recalibration is required, the meter may be returned to the factory or to any authorized distributor.

For frequency and rate measurements with the dual-channel signal conditioner, a calibration correction to the quartz crystal oscillator is stored in EEPROM on the main board. Calibration constants are also stored in EEPROM in the process receiver & totalizer signal conditioner board and in the analog output board. As a result, these two boards can be mixed and interchanged without requiring recalibration.

For frequency calibration using the dual-channel signal conditioner board, calibration may be performed in the field as follows using the front panel pushbuttons:

1. Set *InPut* to *rAtE* and *A only*.
2. Enter 0 in *CALib* to set initial correction to 0 PPM.
3. Set *SCALE* to -9.99999
4. Set *OFFSt1* to 999999
5. Apply a 100 kHz reference signal to channel A.
6. Enter the displayed reading in *CALib*.

For calibration of the process receiver & totalizer signal conditioner board or analog output board, an RS-232 board must be installed in the meter for serial communication with a PC. This board may be removed upon completion of calibration. Calibration software and step-by-step instructions are available from the factory.

## 22. SPECIFICATIONS

### DISPLAY

Type.....6 LED digits, 7-segment, 14.2mm, plus 4 LED indicators  
Digit Color..... Red or green  
Display Range ..... -999999 to +999999

### CONVERSION (FREQUENCY INPUT)

Conversion Technique..... 1/period  
Conversion Rate.....Gate Time + 30 ms + 2 signal periods (max)  
Gate Time..... 0 to 199.99 sec (selectable)  
Time Before Zero Output (Time-Out)..... 0 to 199.99 sec (selectable)  
Output & Display Update Rate..... Same as conversion rate  
Time Base Accuracy..... Calibrated to  $\pm 2$  ppm

### INPUT ISOLATION

CMV from DC to 60 Hz..... Withstand 250Vac  
Dielectric strength..... 3.5 kV ac for 5 sec, 2.3 kV ac for 1 min

### DUAL CHANNEL SIGNAL CONDITIONER

Accuracy at 25°C.....  $\pm 2$  ppm  
Tempco..... $\pm 1$  ppm/degree C  
Long-Term Drift of Crystal .....  $\pm 5$  ppm/year  
Signal Types.....AC, NPN, PNP transistor outputs, contact closures, magnetic pickups  
Max Pulse Rate ..... 1 MHz on Channel A, 250 kHz on Channel B  
Channel Isolation.....Channel A & channel B share common ground  
Low Pass Filter ..... 250 Hz or 30kHz (selectable)  
Hysteresis..... 15 mV to 2.2 Vp-p (selectable)  
Trigger level.....  $\pm 15$  mV to  $\pm 1.7$  V (selectable)  
Debounce Circuitry ..... 0, 3, 50 ms (selectable)

### PROCESS RECEIVER & TOTALIZER SIGNAL CONDITIONER

Signal Levels ..... 0-1 mA, 4-20 mA, 0-10 V (selectable)  
Accuracy at 25°C.....  $\pm 0.025\%$   
Span Tempco .....  $\pm 0.003\%$  of reading /°C  
Zero Tempco .....  $\pm 0.003\%$  of full scale /°C

### QUADRATURE SIGNAL CONDITIONER

Signal Type..... Differential or single-ended quadrature  
Transitions Monitored ..... x1, x2 or x4  
Max Pulse Rate ..... 250 kHz at x1, 125 kHz at x2, 62.5 kHz at x4  
Maximum Differential Signal Amplitude ..... 14V  
Conversion Technique for Rate ..... 1/period  
Conversion Time for Rate..... Gate time + 30 ms + 0-2 signal periods  
Time Before Zero Output for Rate ..... 0 to 199.99 sec (selectable)  
Zero Wait Time for Rate ..... 0 to 199.99 sec (selectable)

Output & Display Update Rate..... Same as conversion rate  
Time Base Accuracy for Rate ..... Calibrated to  $\pm 2$  ppm

### POWER REQUIREMENTS

Input Voltage rating (standard) ..... 95-240V ac  $\pm 10\%$  or 90-300V dc  $\pm 10\%$   
Input Voltage rating (low voltage option)..... 10-34V ac or 10-48V dc  
Power Line Frequency ..... DC and 47-63 Hz  
Power Consumption, Max..... 5 Watts

### EXCITATION OUTPUTS

Voltage & Current Levels (jumper selectable) ..... 5V dc  $\pm 5\%$ , 100 mA max  
10V dc  $\pm 5\%$ , 120 mA max  
24V dc  $\pm 5\%$ , 40 mA max  
Excitation Output Ripple ..... 100 mVp max  
Isolation from power and outputs..... 250 Vac  
Insulation dielectric strength to power and outputs ..... 3.5 kV ac for 5 sec, 2.3 kV ac for 1 min  
Isolation to signal common ..... 50V dc

### DUAL RELAY OPTION

Power to Relay Option..... Powered by meter  
Setpoint Setup ..... Via front panel pushbuttons or RS232/485  
Update Rate ..... 56/s at 60 Hz, 47/s at 50 Hz  
Response to input signal (min) ..... Display update rate  
Input Signal (selectable) ..... Filtered or unfiltered input signal  
Actuation Modes (selectable) ..... Above or below setpoint, latching or non-latching, disabled  
Output Time Delay (selectable) ..... 1 to 128 readings  
Front Panel Enable / Lockout Modes (selectable) ..... 1) Display and change setpoints  
2) Display but do not change setpoints  
3) Neither display nor change setpoints  
Alarm Status Indication..... 2 red LED lamps  
Status Indication Setup (selectable) ..... Lit when output is ON or OFF, or disabled

#### Contact Relay Output:

AC Rating ..... 8A @ 240V ac  
DC Rating ..... 8A @ 24V dc  
Isolation rating between signal common and contacts..... 250V ac  
Insulation dielectric strength between signal common and contacts.....  
..... 3.5 kV ac for 5 sec, 2.3 kV ac for 1 min

#### Solid State Relay Output:

AC Rating ..... 120 mA @ 125V ac, 24 ohms series resistance  
DC Rating ..... 240 mA @ 150V dc, 6 ohms series resistance  
Isolation rating between signal common and contacts..... 250V ac  
Insulation dielectric strength between signal common and contacts.....  
..... 3.5 kV ac for 5 sec, 2.3 kV ac for 1 min

### ANALOG OUTPUT OPTION

Power to Analog Output Option ..... Powered by meter  
Output Levels (voltage & current available simultaneously) ... 0-20 mA or 4-20 mA and 0-10V



Voltage Compliance, 0-20 mA Output ..... 12V (0-600 Ohm load)  
 Current Compliance, 0-10V Output..... 2 mA (5 kOhm or higher load)  
 Accuracy .....Meter input accuracy  $\pm 0.1\%$  of full scale analog output  
 Response Time..... Display update rate  
 Scaling of Reading for Zero Output ..... -999,999 to +999,999  
 Scaling of Reading for Full Scale Output ..... -999,999 to +999,999  
 Isolation rating between signal common and analog output ..... 250V ac  
 Insulation dielectric strength between signal common and analog output .....  
 ..... 3.5 kV ac for 5 sec, 2.3 kV ac for 1 min

**SERIAL INTERFACE OPTION (RS232, RS485, RS485-Modbus boards)**

Power to Interface Option ..... Powered by meter  
 RS485 Wiring.....Half or full duplex  
 Baud Rates .....300, 600, 1200, 2400, 4800, 9600, 19200  
 Serial Protocols..... Custom ASCII\*, Modbus\* RTU, Modbus\* ASCII (selectable)  
 Signal Levels ..... Meet RS232 and RS485 standards  
 Connectors ..... Single RJ11 (RS232), two RJ11 (RS485), two RJ45 (RS485-Modbus)  
 Isolation rating between signal common and serial I/O..... 250V ac  
 Insulation dielectric strength between signal common and serial I/O.....  
 ..... 3.5 kV ac for 5 sec, 2.3 kV ac for 1 min

**PARALLEL BCD OUTPUT OPTION**

Power to BCD Output Option..... Powered by meter  
 Type..... 3-state, stored, parallel  
 Signal Levels .....LSTTL, CMOS compatible  
 Controls ..... BCD Enable, Hold, Data Ready  
 Isolation rating between signal common and BCD output ..... 250V ac  
 Insulation dielectric strength between signal common and BCD output .....  
 ..... 3.5 kV ac for 5 sec, 2.3 kV ac for 1 min

**ENVIRONMENTAL**

Operating Temperature ..... 0°C to 55°C  
 Storage Temperature..... -40°C to 85°C  
 Relative Humidity .....95% from 0°C to 40°C, non-condensing  
 Case ..... NEMA-4X from front when panel mounted  
 Shock..... 10 G at 1 kHz, applied in X, Y, Z axes  
 Vibration ..... 15 Hz to 150 Hz, 1 mm to 2 mm amplitude, 20 G max

## 23. GLOSSARY OF TERMS

### Adaptive filter threshold

A threshold which causes an adaptive moving average filter to be reset to the latest reading when the accumulated difference between individual readings and the filtered reading exceeds that threshold. Adaptive moving average filtering allows a meter to respond rapidly to actual changes in signal while filtering out normal noise. The accumulated difference is also reset to zero when the latest reading has a different polarity than the filtered reading. A low adaptive filter threshold is normally selected. A high filter threshold should be selected if the signal has large transients.

### Alarm, latched

An alarm which stays actuated until reset. Latched alarms can shut down machinery or a process when an operating limit has been exceeded, or maintain an alarm condition until acknowledged by an operator.

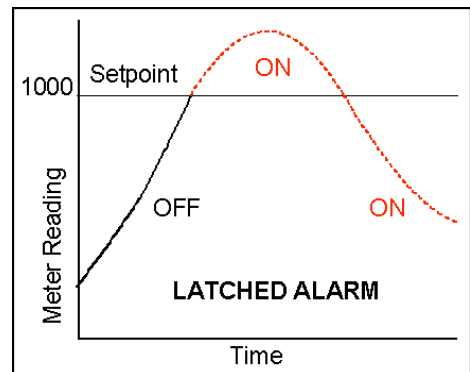

### Alarm, non-latched

An alarm which changes state automatically when the reading rises above a specified limit and changes back automatically when the reading falls below a limit.

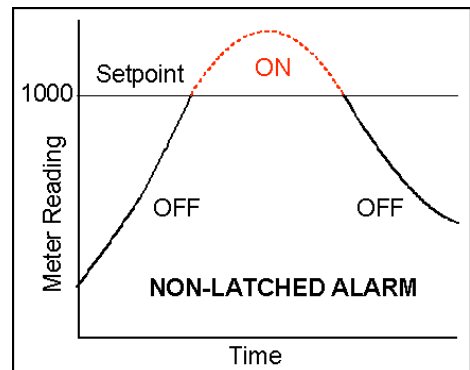

### Autofilter

A selectable digital filter mode which automatically selects an appropriate moving average filter time constant from 0.08 sec to 9.6 sec for the encountered noise condition.

**Batch control** An operating mode of the Extended counter with relay board, where the counter is used to control repetitive fill operations by counting up from zero to a preset, or counting down from a preset to zero.

### Calibration

A process that compensates for inaccuracy in the crystal oscillator used for frequency, rate or time measurement. Calibration compares the meter reading against a known reference frequency. If the reading is lower than the reference, a positive correction in parts per million (ppm) is entered. If the displayed reading is higher than the reference, a negative value in ppm is entered.

### Calculated total

While most totals are based on direct pulse counts, certain totals are calculated as running totals based on displayed rate (e.g., Total A, Rate A). The totalizing process assumes that rate is displayed in units per second, such as 300 gallons per second, allowing a scale factor of 1 to be used. If the rate is not in units per second, a different scale factor has to be applied. For example, with a displayed rate of 300 gallons per minute, a scale factor of 1/60 would need to be applied (scale factor of 1.66667 with a multiplier of .01).

### Coordinates of 2 points method

A scaling method where the coordinates of 2 points are entered. For a pulse rate input, the first entered point would be low frequency in Hz and low desired reading. The second entered point would be high frequency in Hz and high desired reading.

**Counts** The reading displayed on the meter ignoring the decimal point.

### Custom ASCII protocol

A simplified, short protocol for use with panel meters, counters and timers. It allows 31 digital addresses. Not an industry-standard protocol, like the more complex *Modbus protocol*, which is also offered with these instruments.

### Custom curve

A user-specified nonlinear relationship between the input signal and displayed reading. Custom curve linearization is available with the *Extended counter*. One way to supply the data is via a text file with up to 180 data points, which is processed on a PC using furnished software and is then downloaded into EEPROM via serial communications.

**Cutoff** A programmable threshold in units of flow applicable to Total and Batch Control with the process receiver and totalizer signal conditioner. Flow rates below the cutoff, deemed to be zero offset errors, will not be totalized. Otherwise, small zero offset errors could result in a large error if accumulated over a long time.

### Deviation band

A band in counts which controls relay action symmetrically around a *setpoint*. The relay actuates when the reading falls within the deviation band, and de-actuates when the reading falls (e.g., 50 counts) is set up around both sides of the setpoint to create a deviation band (e.g., 100 counts). Setting up a passband around a setpoint is often used for component testing. Deviation limits are programmed by entering menu item *dEU1b* for Alarm 1 and *dEU2b* for Alarm 2. The deviation band will be equal to two limits.

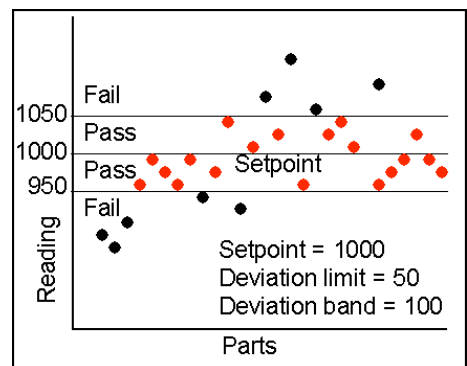

**Display blank** A rear panel input which blanks the display when the input is tied to logic ground by a switch or 0V is applied (logic level true). The meter display will light when the input is open or is held at +5V (logic level false).

**Duty cycle** ON or OFF period of square waves as a percentage of total period over a *gate time* which is selectable from 10 ms to 199.99 sec. With the dual input signal conditioner, the same signal is applied to Channels A and B. Duty cycle can then be read out with resolution to 0.01%.

### Extended counter

A counter with an enhanced microcomputer main board that provides added capabilities, such as *custom curve* linearization of nonlinear inputs and display of rate of change from successive readings.

**Frequency** Rate in cycles per second or Hertz (Hz). In rate meter mode, a scale factor of 1 and offset of 0 cause a display directly in Hertz with resolution of 1 Hz. To increase or decrease resolution, increase or decrease the scale factor.

**Function reset** A rear panel input which resets Peak, Valley and any latched alarms. Latching is achieved by tying the input to logic ground or applying 0V (logic level true). Reset is achieved by opening the input or applying +5V (logic level false).

**Gate Time** A user-specified time interval from 10 ms to 199.99 sec over which the meter measures frequency. The meter times an integral number of signal periods over the gate time, and then taking the inverse of period. The display update rate of the meter is gate time + 1 period + 30 ms. Selecting a longer gate time produces a more stable reading as more cycles are averaged, but slows down the update rate. At very low frequencies, the update rate of the meter is controlled by the period. In totalizing mode, the gate is always open, but the gate time setting still determines the update rate of the meter. See also *Time-out* or *Time before zero output*.

**Jumper** A push-on component which provides a short between two adjacent posts on a circuit board. Jumpers are used to configure the circuit board, for example for different signal ranges. Jumper positions are not sensed by the meter software.

**Hysteresis band**

A band in counts which controls relay action symmetrically around a setpoint. The relay closes (or opens) when the reading goes above the setpoint plus one hysteresis limit, and opens (or closes) when the reading falls below the setpoint less one hysteresis limit. A narrow hysteresis band is often used to minimize relay chatter around a setpoint due to electrical noise or signal feedback caused by load switching. A wide hysteresis band can be used for control applications. Hysteresis limits are programmed by entering menu item dEU1H for Alarm 1 and dEU2H for Alarm 2. The hysteresis band will be equal to two hysteresis limits.

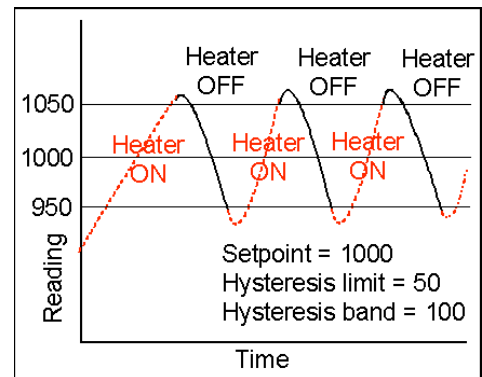

**Item #** Also called Display Item. A numerical value in the meter available for display under control of a front panel key or serial communications. For example, in the A+B totalizer mode, the sum of A+B is Item #1, Total A is Item #2, and Total B is Item #3. When the meter is reset, Item #1 is always displayed. To view another Item, press the *RESET* key. For Item 1, the yellow View “V” LED is unlit. For Item 2, the “V” LED is lit. For Item 3 the “V” LED flashes.

**Menu mode** Meter programming mode used for input and range selection, setup, and configuration. Entered into from the Run mode by pressing the MENU key. The Menu mode can be locked out completely by a jumper on the power supply board.

- Meter Hold** A rear panel input which freezes the meter display and all meter outputs while that input is tied to logic ground by a switch or is held at 0V (logic level true). The meter will resume operation when the input is disconnected or is held at +5V (logic level false).
- Modbus** An industry-standard serial communications protocol which allows devices by different manufacturers to be digitally addressed by a PC on the same communication line, with up to 247 digital addresses. More complex than the *Custom ASCII* protocol, which is also supported by these meters.
- Moving average filter**  
A digital filter mode which displays a weighting moving average of readings. Eight moving average modes are selectable with the following equivalent RC time constants: no filter, 0.1 sec, 0.2 sec, 0.4 sec, 0.8 sec, 1.6 sec, 3.2 sec, 6.4 sec.
- Multiplier** A constant multiplier from 0.00001 to 100000 (in decade steps) that is combined with a *scale factor* from 0.00000 to 9.99999 (fixed decimal point and settable digits) to go from frequency in Hz to rate in engineering units such as gallons per minute or from pulse counts to total in engineering units, such as gallons. The combination of a 6-digit scale factor with a multiplier provides more dynamic range with no loss of resolution than could be achieved with a 6-digit scale factor only.
- Offset** A constant adder to the displayed reading. This may be any value from -999,999 to 999,99. The offset may be used as a preset in the totalize mode, where the total can be counted down from the preset to zero.
- Peak display** The maximum (or most positive) reading since that value was last reset. Reset can be via the meter front panel, an external input, or a software command. The displayed value can reflect the filtered or unfiltered readings.
- Period** The time of one complete cycle of the input frequency. A scale factor of 1 and multiplier of 1 produce a display in microseconds.
- Phase angle** The lead or lag in degrees between two AC signals of the same frequency. With the signals applied to Channels A and B of the dual input signal conditioner, phase angle can be displayed from -180° to +180° with resolution to 0.01°.
- Pulses** Voltage waveshapes with leading and trailing edges that are detected for determination of frequency, period or time. With the quadrature signal conditioner, the menu item *Pulses* is used to set the number of pulses generated by a quadrature encoder for each zero index pulse. This setting is equal to the number of pulses per revolution of the encoder (times 2 or 4 if the count by 2 or 4 is selected on the signal conditioner) times the scale factor.
- Process signal**  
An analog signal whose display requires setup of *scale* and *offset* for display in engineering units (such as psi). The process receiver & totalizer signal conditioner accepts 0-1 mA, 4-20 mA or 0-10 V process signals.

- Quadrature** A quadrature encoder generates 2 signals that are 90° out of phase based on the position of a rotor or linear scale. The phase relationship of these signals depends on the direction of rotation of the encoder. The meter counts up or down depending on the phase. Quadrature is used for very accurate determination of length or position.
- Rate** Same as frequency, except that a *scale factor* and *multiplier* have been applied to convert the reading in Hz to a reading in engineering units, such as revolutions per minute or gallons per hour.
- Remote Display**  
A display mode which allows the meter to serve as a 6-digit remote display when connected to a computer or other meter via a serial communications link. A serial communications option board is required in the meter.
- Reset** Two types of Reset are applicable to counter/timer operation:
- Peak and Valley Reset. Achieved by simultaneously pressing the *RESET* and *PEAK* keys.
  - Latched Alarm Reset. Achieved by simultaneously pressing the *RESET* and *ALARMS* keys.
- Resolution** A menu item which controls the resolution of arithmetic functions (A+B, A-B, AxB, A/B, A/B-1) of Grand Total in batch mode. It multiplies the displayed value by a factor of 0.00001 to 100,000 in decade steps. The decimal point then has to be moved appropriately.
- RS485 half duplex**  
Serial communications implemented with two wires, allowing data transmission in both directions, but not simultaneously.
- RS485 full duplex**  
Serial communications implemented with four wires, allowing data transmission in two directions simultaneously.
- Run Mode** The normal operating mode of the meter, where readings are taken, as opposed to the *menu mode*.
- Scale factor** A constant multiplier used to go from a raw reading in pulses per second or total pulses to a reading in engineering units. The scale factor consists of a scale value from 0.00000 to 9.99999 (fixed decimal point, settable digits) and a scale multiplier from 0.00001 to 100000 (in decade steps). The combination of a 6-digit scale factor with a multiplier provides more dynamic range with no loss of resolution than could be achieved with a 6-digit scale factor only.
- Scaling** The process of setting *scale* and *offset* so that the meter reads properly in engineering units (such as gallons/minute).
- Scaling, coordinates of 2 points method**  
A scaling method where four numbers are entered manually: low input, desired reading at low input; high input, and desired reading at high input. The meter then applies a straight line fit. The decimal point is set by the separate *dEC.Pt1* menu item.

**Scaling, scale and offset method**

A scaling method where *scale* and *offset* are entered manually.

**Setpoint**

A value compared to the reading to determine the state of a relay. Term often used interchangeably with “alarm setpoint.” The relay action can be by *latching* or *non-latching*, utilize a *hysteresis band*, or utilize a *deviation band*. Hysteresis bands and deviation bands are specified by two symmetrical limits around the *setpoint*.

**Stopwatch mode**

A timing operating mode for single events. Stopwatch A-to-A measures time between the same positive (or negative) edge of start and stop pulses applied to Channel A. Stopwatch A-to-B measures time between a start pulse on Channel A and a stop pulse on Channel B.

**Time interval mode**

An timing operating mode for the average duration of repetitive events over a programmed gate time. Time may be measured from the leading or trailing edge of pulses applied to Channel A to the leading or trailing edge of pulses applied to Channel B.

**Time-out (or time before zero output)**

The time the meter waits for a signal to start or end a conversion. If pulses are not received before the time-out ends, the meter reads zero. The longer the time-out, the lower the minimum frequency the meter can display. This term is also used for the programmable time that the batch relay stays de-energized at the end of a batch cycle.

**Valley display**

The minimum (or most negative) reading since that minimum was last reset. Reset can be via the meter front panel, an external input, or a software command. The displayed value can reflect the filtered or unfiltered readings.

## 25. WARRANTY

**Yokogawa Corporation of America** warrants its products against defects in materials or workmanship for a period of one year from the date of purchase.

In the event of a defect during the warranty period, the unit should be returned, freight prepaid (and all duties and taxes) by the Buyer, to the authorized Yokogawa distributor where the unit was purchased. The distributor, at its option, will repair or replace the defective unit. The unit will be returned to the buyer with freight charges prepaid by the distributor.

### **LIMITATION OF WARRANTY**

The foregoing warranty shall not apply to defects resulting from:

1. Improper or inadequate maintenance by Buyer.
2. Unauthorized modification or misuse.
3. Operation outside the environmental specifications of the product.
4. Mishandling or abuse.

The warranty set forth above is exclusive and no other warranty, whether written or oral, is expressed or implied. Yokogawa specifically disclaims the implied warranties of merchantability and fitness for a particular purpose.

### **EXCLUSIVE REMEDIES**

The remedies provided herein are Buyer's sole and exclusive remedies. In no event shall Yokogawa be liable for direct, indirect, incidental or consequential damages (including loss of profits) whether based on contract, tort, or any other legal theory.